

1. 机器简介

1. Introduction to machine

GA254 型大旋梭特厚料上下送料平缝机是单直针、连杆挑线、高精度螺旋伞齿轮传动、大旋梭勾线。由于采用特殊的上送料机构，所以它除了具有一般上下送料缝纫机的各项性能外，其最大的优点是对特厚缝料和较粗的缝线也能正确自如地进行。

GA254 upper and lower feed lockstitch for the heavily and most bulky materials is featured with single needle, link take-up lever, high precision screw gear driver and big rotating hook. Besides the capabilities possessed by ordinary upper and lower feed sewing machine, the biggest strongpoint is that it can work smoothly on the heavy sewing material and thick sewing thread due to its special upper feed structure.

该系列产品广泛地适用于箱包、皮革、沙发、帐篷、凉席等行业。

This series is suitable for sewing on boxes, bags, leather workpiece, sofa, tent and mat etc.

3. 操作准备

3. Operating preparation

1 擦拭机器 Machine cleaning

机头装箱前为了防止机件生锈，各部分均涂有较厚的防锈油脂，同时机头装箱后，还可能在较长的贮藏和长途阶段造成油脂硬化和积聚在机器表面的灰尘，所以必须将表面的油脂和灰尘用汽油和软布拭擦干净。

To prevent parts getting rusty, thick antirust grease will be smeared thoroughly on machine head before putting it in box. After that, grease may become sclerous due to long-time storage and long-distance transportation and dirt may also accumulate on the surface of the machine. The grease and dirt on the surface must be cleaned with gasoline and soft cloth.

2 检查 Checking

机器出厂时，虽经过周密的检查和实验，但在长途运输中也可能受到强烈的振动使机件松动或歪曲，所以应该做一次周密细致的检查，并用手轻轻转动主动轮，看机件之间有无转动困难，碰撞现象或其他不均匀阻力，不正常的声响，如有应作适当的调整，机器情况正常后方可正式试车。

Although thorough checking and testing has been made before machine leave factory, one more careful checking is needed for the parts of the machine might loosened or distorted by strong vibration during long-distance transportation. Turn the driver gently by hand to see whether it has running difficulty among parts, with/without collision or other uneven resistance or abnormal sounds. Adjust must be made if abnormality exists. Trial run cannot start before all become normal on machine.

4. 安装电机 (图 1)

4. Install electromotor (figure 1)

将电动机 (C) 左右移动，使缝纫机主动轮槽 (A) 与电动机皮带轮槽 (B) 的位置调整成一线即可。

Move the motor (C) left and right, and make the positions of the driver groove (A) sewing machine and the belt wheel groove (B) of the motor in line.

2. 主要技术规格

2. Main technical specifications

型号 model	254
参数 Parameters	
最高缝纫速度 Max. sewing speed	1400s.p.m.
最大线迹长度 Max. stitch length	13mm
压脚提升高度 Presser foot lifting height	手动 13mm 脚踏 13mm 以上 13mm by hand, 13mm above with pedal
交替压脚升降幅度 Alternate presser foot range	4mm-6mm
最长针距 Presser foot synchronized with feed dog	12.7mm Max stroke no less than 12.7mm
采用旋梭 Rotating hook	特大型旋梭 Oversize rotating hook
采用机针 Needle	DD×1 24#-27#
润滑方式 Lubricating type	手工加油 Lubricate by hand
电动机功率 Electromotor power	0.5 千瓦 (缝纫机专用) 0.5kw(only for sewing machine)

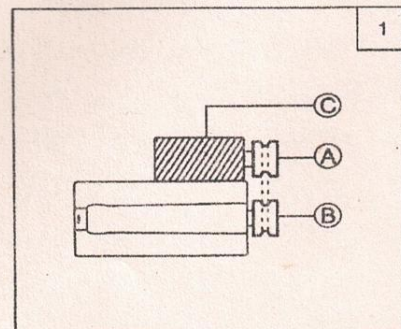

5. 脚踏板与离合器拉杆连接 (图 2)

5. Connect pedal with clutch lifting rod (figure 2)

A. 脚踏板安装的倾斜度应与地面成 15 度角为宜。

The suitable gradient between pedal installed and floor is 15°

B. 调整电机离合器, 使缝纫机拉杆 (B) 与离合器拉杆 (C) 如图连成一直线, 可使电机运转平稳, 寿命延长。

Adjust the motor clutch, and make the lifting rod (B) of the sewing machine and hat (C) of the clutch in line (see figure), so as to make motor run smoothly and its life span extended.

C. 缝纫机运转方向, 从机头主动轮外侧看, 应是逆时针方向, 与电动机的转向应一致。其转向可用电动机插头换转 180 度调整转向。

Look from the exterior part of the machine head driver, the running direction of the sewing machine is anticlockwise. Its running direction should accord with that of the motor, and can be adjusted with turning 180° of the motor plug.

D. O 型三角皮带 (F) 的张力调整, 由电动机移动上下位置来达到。皮带张力的大小可用手指将皮带按下, 使皮带如图所示弯曲成 10-12 毫米程度即可。

Moving the position of motor up and down can make the tension adjustment of the O triangular belt (F). Press the belt with finger to test the tension of the belt, and the belt should bend 10-12mm (see figure).

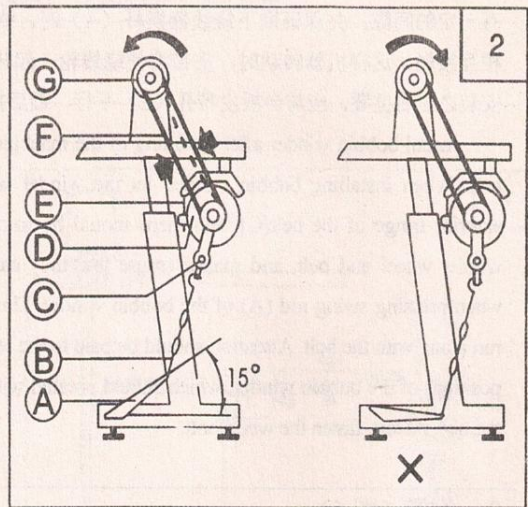

6. 抬压踏板连接 (图 3)

6. Connect presser-lifting pedal (figure 3)

先用拉链钩 A 连接压脚提升拉链 B 和压脚提升杆 C, 然后将脚踏板组件 D 安放在机架横档上, 左右移动控制板 E, 使拉链连成一直线, 接头用螺栓和螺母紧固, 最后用拉链钩勾住控制板即可。

Firstly, connect the presser foot lifting zipper B and presser foot lifting rod C with zipper hook A, then place the pedal subassembly D on the stand, and move the control plate E left and right to make zippers in line. The tie-in is fastened with nut and bolt. Finally, hitch the control plate with zipper hook.

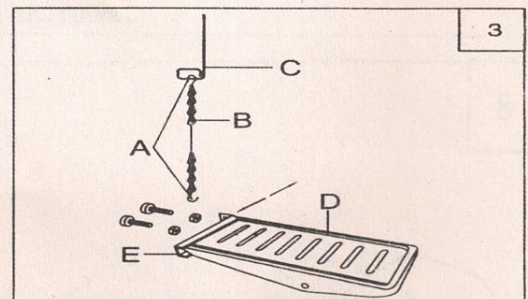

7. 安装皮带防护罩 (图 4)

7. Install belt shield (figure 4)

从安全角度考虑, 应安装皮带防护罩。

For safety consideration, the belt shield should be installed.

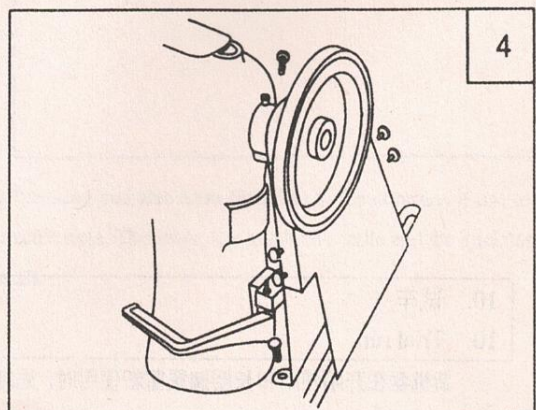

8. 安装绕线器 (图 5)

8. Install bobbin winder (figure 5)

机头, 套上皮带后, 就可以着手装绕线器, 安装绕线器时, 先将绕线轮 (B) 对准皮带 (C) 的外边, 绕线轮和皮带之间应有一定的间隙, 并保证按下绕线器摆杆 (A) 时, 绕线轮和皮带能保持相互接触。这样机器转动时, 皮带将使绕线轮一起转动, 并注意绕线器安装之左右位置, 应与台板皮带孔 (E) 平行, 最后拧紧木螺钉。

Install bobbin winder after installing of the machine head and fixing the belt. When installing bobbin winder, let the winder wheel (B) aim at the exterior fringe of the belt (C), and there should be some clearance between winder wheel and belt, and makes assure that they can contact each other when pressing swing rod (A) of the bobbin winder. Thus, winder wheel will run along with the belt. Attention should be paid to the left and right installing positions of the bobbin winder, which should parallel with the belt hole (E) of the bed. At last, fasten the wood bolt.

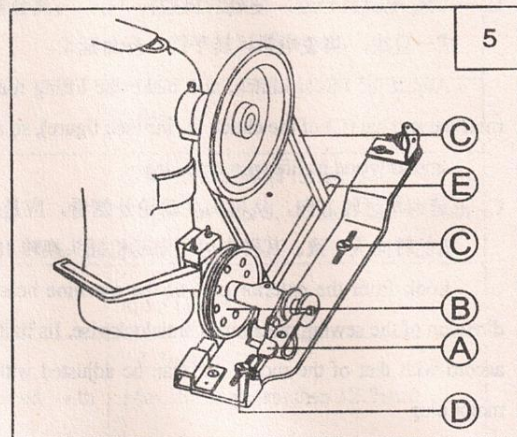

9. 润滑 (图 6)

9. Lubrication (figure 6)

每天机器工作结束后在红色标记处加足够的油, 然后再让机器运转 1-2 分钟。

Add enough lubricating oil at the position of the red marker after finishing work at the end of day, and then run the machine for 1-2 minutes.

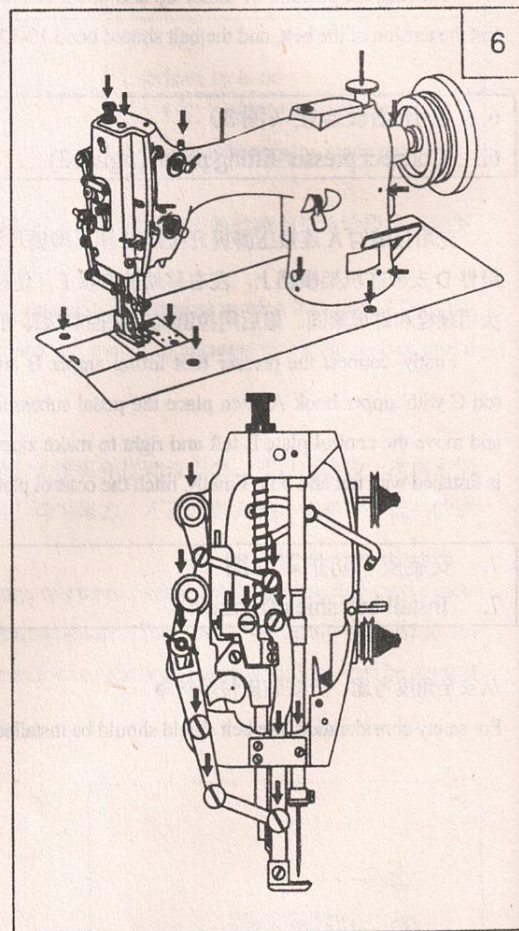

10. 试车

10. Trial run

新机器在开始使用和长期搁置重新使用时, 先卸下机头上部的橡皮塞和面板, 充分加油。然后抬起压脚进行低速运转 300-400 针/分, 润滑正常后, 仍须保持 30 分钟的运转试验, 以后逐步提高缝纫速度, 经过一个月左右的使用, 使机器充分磨合。然后并

据工作的性质再提高到一定缝速。

Before using new machine or reusing a machine being laid aside for a long time, please demount the rubber plug and faceplate on the top of machine head, and add enough lubricating oil. After that, lift the presser foot, and let the machine run at a low speed of 300-400s.p.m. Please keep running test for 30 minutes with thorough lubrication, and then increase the sewing speed gradually. Machine will become harmonious after using for about one month. Sewing speed can then increase according to the nature of the work.

11. 安装机针 (图 7)

11. Install machine needle (figure 7)

转动上轮, 使机针上升到最高位置, 旋松夹针螺钉 1 将机针的长槽朝向操作者的左面, 然后把针柄插入针杆下部的针孔内, 使其碰到针杆孔的底部为止, 再旋紧夹针螺钉 1 固定机针即可。

Turn the upper wheel, and make the machine needle move up to the top position. Loosen the needle clamp bolt 1, and let the long groove of the machine needle face the left side of the operator, and then insert the needle bar in the needle hole at the lower part of the needle rod. Fasten the needle clamp bolt 1 and fix the machine needle when the needle bar touches the bottom of the needle rod hole.

注意: 如图 (b) 所示, 机针没有碰到针杆孔的底部。如图 (c) 所示针槽方向面对操作者, 都是错误的。

Notice: as figure (b) showing, machine needle does not touch the bottom of the needle rod hole. As figure (c) showing, the direction of the needle groove is facing the operator, both are wrong.

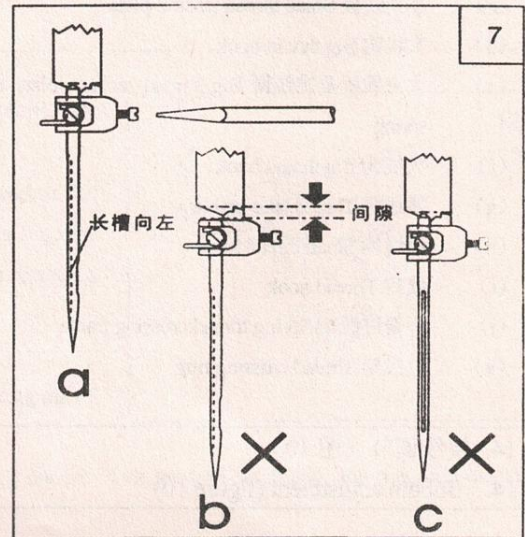

12. 机针、缝线和缝料的配合 (图 8)

12. Match the machine needle with sewing thread and sewing materials (figure 8)

面线采用左捻线, 底线则左右捻均可使用。缝线捻向的鉴别, 可按图 10 所示把缝线捏住, 以右手按图箭头方向搓转缝线, 若线股越搓越紧, 则是左捻线, 反之即是右捻线。请使用 DD×1 型 24#-27# 型机针, 机针的粗细应适合缝料的性质。如用过细的机针缝制紧厚的织物, 机针就容易折断, 也会因引起跳针、断线等现象。相反, 如果用过粗的机针缝制紧密的织物, 则会因针孔太大而损坏织物。所以应根据缝料性质不同, 机针和缝线的粗细都要适当的进行选择。

Upper thread should be left-twisted thread, and the bottom thread can be left twist thread or right-twisted thread. As figure 10 showing, we can determine the twist direction of the sewing thread. Twist the sewing thread in arrow direction showed in figure, and if the thread gets tightened, it should be the left -twisted thread; otherwise it should be the right-twisted thread. Please use 24#-27# machine needle, and thickness of the needle should match the nature of the sewing material. If use too thin needle to sewing

thick textile, the needle can easily get broken, and needle skipping and stitches breaking can also arise from it. On the contrary, if use too thick needle to sew thick textile, the textile can also get damaged due to too big needle hole. Therefore, the machine needle and the thickness of the sewing thread should be chosen according to the nature of the sewing materials.

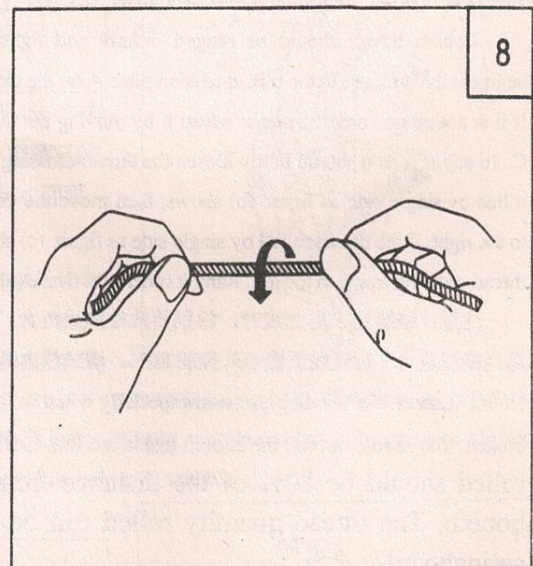

13. 穿面线 (图 9)

13. Upper threading (figure 9)

穿面线时针杆应在最高位置, 然后将线架上引出线头按顺序穿线。

Needle bar should be put at the highest position when crossing the upper thread, and then cross thread ends on the thread frame in order.

- (a) 长过线钉 Long thread crossing nail
- (b) 小过线钩 Small thread crossing hook
- (c) 小夹线板 Small thread tension plate
- (d) 大线钩 Big thread hook
- (e) 大夹线板及挑线簧 Big thread tension plate and thread take-up spring
- (f) 大线钩 Big thread hook
- (g) 挑线杆 Thread take-up bar
- (h) 小线钩 Small thread hook
- (i) 线钩 Thread hook
- (j) 弹簧过线架 Spring thread crossing frame
- (k) 过线架 Thread crossing ring

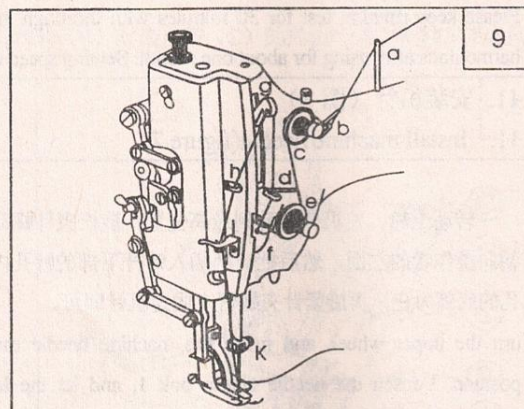

14. 绕线调节 (图 10)

14. Bobbin adjustment (figure 10)

梭心线应排列整齐而紧密。如松浮不紧, 可以加大过线架夹线板 A 的压力。如排列不齐, 则要移动过线架 C 的位置进行调整。调整时, 先松开过线螺钉 B, 单边绕线成图 (b) 时, 向右移动过线架; 单边绕成(c)时, 向左移动过线架。使之能自动排列整齐成图 (a) 后, 再紧固之。

Bobbin thread should be ranged orderly and tightly. If it seems lax, augment the pressure to the thread tension plate A on the thread-crossing frame. If it is not ranged orderly, please adjust it by moving the thread-crossing frame C. To adjust it, you should firstly loosen the thread-crossing bolt B. If the thread rolled by single side as figure (b) shows, then move the thread-crossing frame to the right; if the thread rolled by single side as figure (c) shows, then move the thread-crossing frame to the left. Rang it orderly as figure (a) shows, and then fasten it.

注意: 绕涤纶、尼龙线时, 特别要放松绕线压力。否则梭心 D 就可能产生断裂变形。梭心线不要绕的过满, 否则容易散落。适当绕线量为平行绕线至梭心外径的 80%。绕线量由满线跳板上的满线度调节螺钉 E 加以调节。

Notice: Loosen the winding pressure especially when rolling the terylene and nylon thread, otherwise, the bobbin D will get deformed or broken. You should not roll the bobbin thread too full. Otherwise, it may disperse easily. The suitable thread quantity rolled should be 80% of the distance from the parallel thread rolled to the exterior diameter of the bobbin. The thread quantity rolled can be adjusted by full thread adjusting bolt E on the full thread springboard.

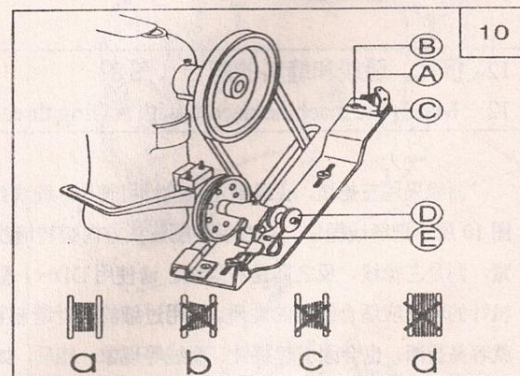

15. 针距、倒顺缝误差调节 (图 11)

15. Stitch length, forward and backward stitching error adjustment (figure 11)

针距的长短, 可以用针距调节扳手 A 来调节。左手按下针距调节扳手, 同时右手转动皮带轮 B, 如顺时针转动针距变大, 逆时针转动针距变小。调节结束后用一张纸来试一下针距长短, 直到满意为止。然后再观察倒、顺缝线迹是否一样长, 如果倒缝短, 则逆时针旋松螺丝 C, 再紧固其螺母; 如倒缝比顺缝线迹长, 则相反。也可以调节螺丝

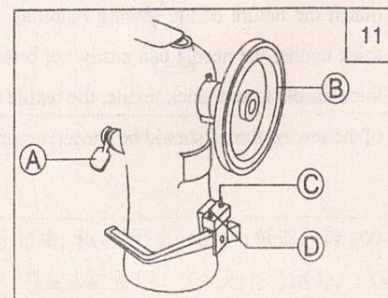

D 来达到相同的目的。

The stitch length can be adjusted by stitch length adjusting spanner A. Press the stitch length adjusting spanner with your left hand, and turn the belt wheel B with your right hand. The stitch length will be shortened when you turn the wheel clockwise; and it will become extended when you turn the wheel anticlockwise. After adjustment, test the stitch length with a piece of paper to get satisfactory results. Then take a look whether the length of the forward and backward stitch is the same. If the backward stitch is shorter, loosen the bolt C anticlockwise, and then fasten the bolt; if the backward stitch is longer than forward stitch, adjust it oppositely. You may achieve the same goal with adjusting bolt D.

16. 挑线部位进油 (图 12)

16. Lubricating at thread take-up position (figure 12)

挑线, 针杆部位采用羊毛软线进油。长期使用后, 如失去正常的进油作用, 软(油)线被污染或硬化, 就应更换新的羊毛软线。更换方法如下:

Take-up thread and needle bar should be lubricated with soft wool oil thread. If the soft (oil) thread was polluted or became sclerous and lost the normal lubricating function after long-time use, it should be replaced with a new soft wool oil thread. The replacing method is as following:

1、打开机头面板, 卸下调节螺钉, 调压螺钉锁紧螺母和调节杆等。

Open the face plate of the machine head, take down the adjusting bolt, locking nut of the pressure-adjusting bolt and adjusting bar etc.

2、卸下挑线连杆销 A, 然后拉出里面的软油线。Take down the connecting bar pin A of the take-up thread, and then pull out the soft oil thread.

3、拉出 B 里的软油线。Pull out the soft oil thread in B.

4、重新更换新油线。Replace a new oil thread.

5、安装的过程是上述过程的相反。The installing process is opposite from above process.

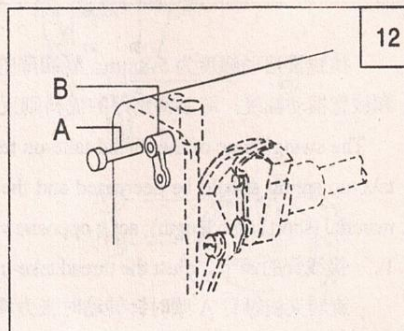

17. 压脚压力调节 (图 13)

17. Adjust the pressure of the presser foot (figure 13)

压脚的压力要根据缝料的厚度加以调节, 首先旋松调压螺钉锁紧螺母 A。缝料厚时, 应加大压脚压力, 这时将机头顶部的调压螺钉按 a 所示的方向转动; 缝薄料时, 可按 b 所示的方向转动调压螺钉, 以减少压脚的压力。最后旋紧调压螺母 A 即可。压脚的压力, 应以能正常推送缝料为宜。

Considering the thickness of the sewing material, the pressure of the presser foot can be adjusted by loosening the locking nut A of the pressure-adjusting bolt. If the sewing material is thick, turn the pressure-adjusting bolt at the top of the machine head in the direction as a shows in figure so as to increase the pressure of the presser foot, or turn the pressure-adjusting bolt in the direction as b shows in figure so as to decrease the pressure of the presser foot when the sewing material is thin. Finally, you should fasten the pressure-adjusting nut A. If it can normally push the sewing material, the pressure of the presser foot can be judged as suitable.

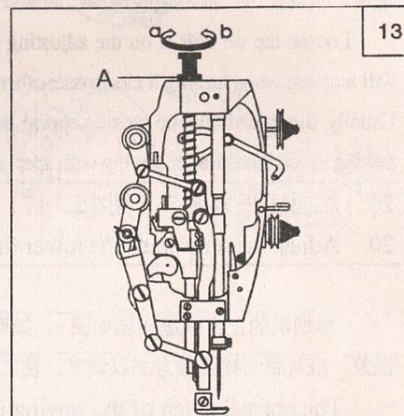

18. 安装梭心与缝线张力调节 (图 14)

18. Install bobbin and adjust the tension of the sewing thread (figure 14)

线的张力要根据缝料的差别, 缝线的粗细以及其它一些因素变动。实际使用中, 是根据缝纫出来的线迹, 来调节底、面线的张力使之得到正常的线迹。

The tension of the sewing thread should be adjusted according to the difference of the sewing material, the thickness of the sewing thread and other factors. In the real sewing

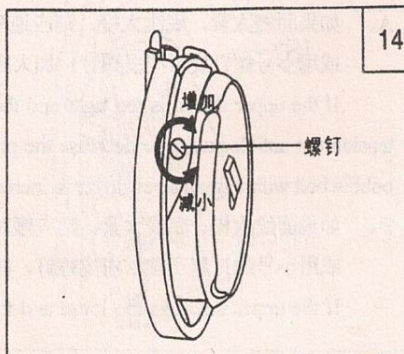

operation, we can adjust the tension of the lower and upper thread with the sewing stitch so as to obtain a normal stitch.

底线张力调整, 只要用小号螺钉起子加大或减少底线压力即可。

The tension of the lower thread can be adjusted by increasing or decreasing the pressure of the it with a small screwdriver.

面线张力以底线张力为基础, 面线张力调整, 主要变换夹线组件中挑线簧张力, 挑线簧摆动幅度、夹线簧张力、夹线板及线勾的位置等。

Upper thread tension is on the basis of the lower thread tension. You may adjust the upper thread tension mainly by changing the tension of the take-up thread spring in thread tension subassembly, swing range of the take-up thread spring, tension of the thread tension spring, thread tension plate and the position of the thread hook etc.

19. 挑线簧调节 (图 15)

19. Adjust the thread take-up tension spring (figure 15)

挑线簧摆动幅度为 5-8mm。缝纫薄的缝料 (短针距) 则要减弱挑丝簧的张力和放宽摆动幅度, 缝制特别厚的缝料则反之。

The swing range of the thread take-up tension spring is 5-8mm. The tension of the take-up spring should be decreased and the swing range increased when sewing thin material (short stitch length); act it opposite when sewing the most thick material.

1、挑线簧的调节。Adjust the thread take-up tension spring

旋转夹线螺钉 A 顺时针转动时张力增加, 反之减少。

Turn the thread tension bolt A. The tension will increase when turning it clockwise; otherwise, the tension will decrease.

2、挑线簧摆动幅度的调节 Adjust the swing range of the thread take-up tension spring

旋松夹线调节座固定螺钉 A, 转动夹线器 B, 调节其摆动幅度, 夹线器 B 顺时针转动, 摆动幅度增大, 反之减少。通常, 机器在出厂前, 挑线簧均已调整妥善。只是在缝料或特殊的缝料时, 才需要重新进行调节。

Loosen the set bolt A on the adjusting frame of tension thread, turn the tension device B and adjust its swing range. The swing range will increase when turning it clockwise; otherwise, the range will decrease.

Usually, the thread take-up tension spring had been adjusted well before the machine left the factory. It is necessary to adjust it only when sewing special material or sewing with special thread.

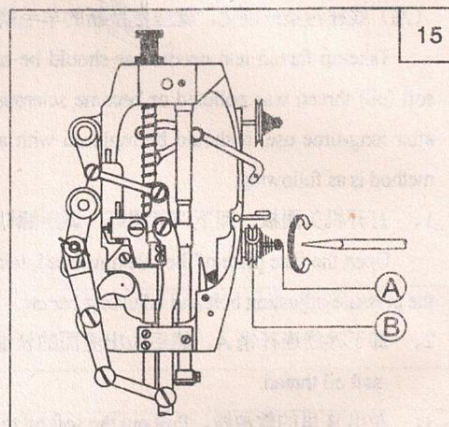

20. 底面线张力调节 (图 16、17)

20. Adjust the tension of the lower thread (figure 16,17)

缝纫机的正常线迹应该如图 a, 如果线迹不正常, 会出现缝料起皱和断线现象, 应对底面线的张力加以调节。使之达到正常的线迹。

The normal stitch of the sewing machine should look like as figure a shows. If the stitch is not normal, sewing material will pucker or the stitch will break; meanwhile, you should adjust the tension of the lower thread to obtain normal stitch.

A、如果面线太紧, 底线太松, 则应逆时针旋转夹线螺母, 放松面线的压力。或用小号螺钉旋紧梭皮螺钉, 加大底线的压力。

If the upper thread is too tight and the lower thread too loose, turn the thread tension nut anticlockwise to decrease the pressure of the upper thread, or fasten the bobbin bolt with a small screwdriver to increase the pressure of the lower thread.

B、如果面线太松、底线太紧, 则应顺时针旋转夹线螺母, 以加大面线的压力或用小号螺钉起子旋松梭皮螺钉, 减小底线的压力。

If the upper thread is too loose and the lower thread too tight, turn the thread

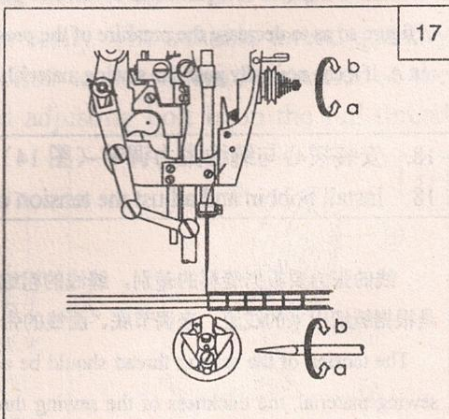
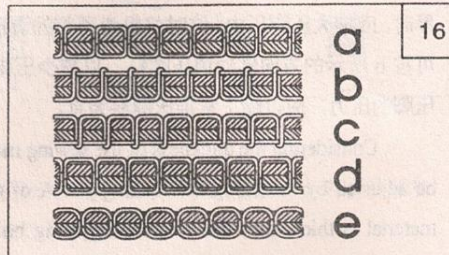

tension nut clockwise to increase the pressure of the upper thread, or loosen the bobbin bolt with a small screwdriver to decrease the pressure of the lower thread.

C、如出现图 d、e 的线迹，也可以参照上述方法加以调节。

If the stitch appears like as figure d or e shows, you may adjust it referring the above methods.

21. 机针与旋梭同步调节 (图 18、19)

21. Synchronous adjustment to the needle and the rotary hook (figure 18,19)

1、机针位置的调节 Adjust the needle position

用手转动主动轮，使针杆 (B) 下降至最低位置，卸下面板 (A)，上下移动针杆 (B) 初步定出同步位置 (针杆的同步位置，当针杆下降至最低位置时，机针线孔的中心 (C) 应与旋梭内周面 (D) 在同一位置上。

Turn the driver with your hand, and make the needle bar (B) drop to its lowest position. Then, take down the faceplate (A), move the needle bar up and down to set the original synchronous position (synchronous position of the needle bar). When the needle bar drops to its lowest position, the center of the needle hole (C) should be at the same position of the interior circle surface.

2、旋梭的同步调节 Synchronous adjustment to the rotary hook

旋梭和机针之间的相互运动关系，对缝纫机性能的影响很大。标准的同步关键是：用手转动轮、使机针向下运动到最低位置后再向上回升 3.8 毫米，这时旋梭钩线尖 (D) 应于机针的中心线 (C) 一致，在此位置时，钩线尖 (D) 应高于机针孔 (E) 上面约 2-2.5mm。

The interacting relation between the rotary hook and machine needle has great influence to the sewing performance. The standard synchronization is: turn the driver with your hand. Make the needle move downward to the lowest position, and then return upward for 3.8mm; meanwhile, the rotary hook thread tine (D) should be consistent with the central line of the needle (C). At this position, hook thread tine (D) should be higher than machine needle hole (E) for 2-2.5mm.

在调节旋梭的同步关系时，还要注意到旋梭尖与机针侧面的间隙。机针 (D) 缺口，底部与旋梭钩线尖 (C) 的间隙为 0-0.1mm。

The clearance between the rotary hook tine and the side of the needle should be noticed when adjusting the synchronous relations of the rotary hook. The clearance between the bottom of the needle (D) indentation and the hook thread tine of the rotary hook is 0-0.1mm.

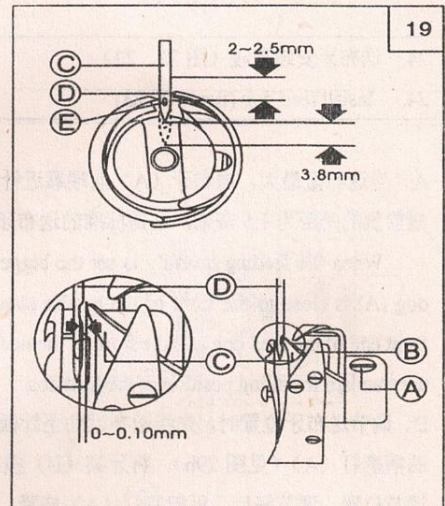
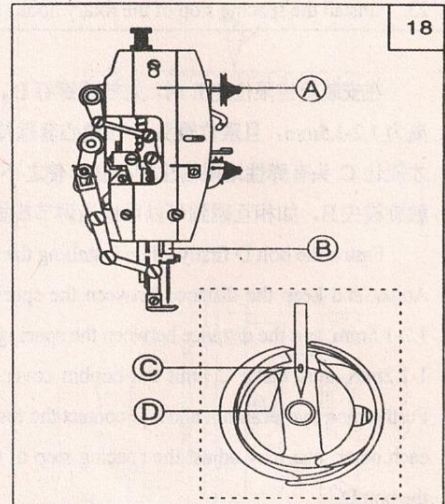

22. 旋梭装卸 (图 20)

22. Assemble and unassemble rotary hook (figure 20)

先将针杆上升到最高位置，拆下针板，取下机针和梭心套。旋开旋梭定位螺钉 (C)，把旋梭定位钩 (A) 取下。再旋松旋梭螺钉 (B)。使旋梭在它的转动轴上能够自由转动，接着用手转动上轮，使送料牙架走向高处。到此可以用手去旋转旋梭，使它让过牙架徐徐取出。安装旋梭上是上述过程的回复。

Firstly, lift the needle bar to the highest position; take down the needle plate, machine needle and bobbin cover. Unscrew the set hook bolt (C) of the rotary hook, and take down the set hook of the rotary hook. Then, loosen the rotary hook bolt (B), so as to make the rotary hook move freely on its driving shaft. Turn the upper shaft with your hand to make the feed frame move higher. Now, turn the rotary hook with your hand and take it out slowly. The installing process of the rotary hook is opposite to the above process.

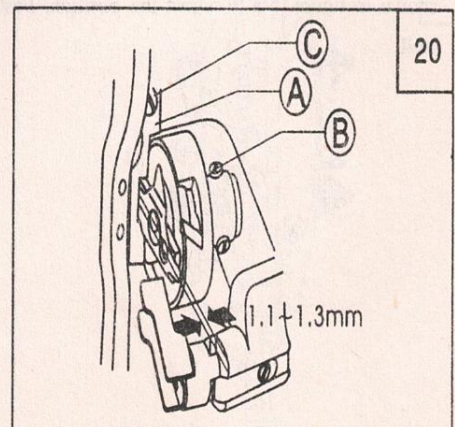

旋梭定位钩的安装位置应是旋梭定位钩 (A) 的沟槽侧面与梭心套头的侧面应成一致。另外其两侧面之间的间隙为 1.1-1.3 毫米。

The installing position of the set hook of the rotary hook is to make the groove side of the set hook (A) consistent with the side of the bobbin cover. Furthermore, the clearance between those two sides is 1.1-1.3mm.

23. 安装旋梭限位座 (图 21)

23. Install the spacing stop of the rotary hook (figure 21)

在安装旋梭限位座 E 时, 先拧紧螺钉 D。调整限位架与旋梭之间的距离为 1.2-1.5mm, 且限位簧头 C 与梭心套保持 1-1.2mm 距离的弹性, 这样才能让 C 头有弹性地限制住梭心套, 使之不脱落。还有, 不能让 C 头接触旋梭尖 B, 如相互碰到可以再适当调节旋梭限位座, 最后拧紧螺钉 D。

Fasten the bolt D firstly when installing the spacing stop of the rotary hook. Adjust and keep the distance between the spacing frame and the rotary hook 1.2-1.5mm, and the distance between the spacing spring C and the bobbin cover 1-1.2mm, thus make C limit the bobbin cover elastically without falling off. Furthermore, you can not allow C contact the rotary hook tine B. If they contact each other, you may adjust the spacing stop of the rotary hook. Finally, fasten the bolt D.

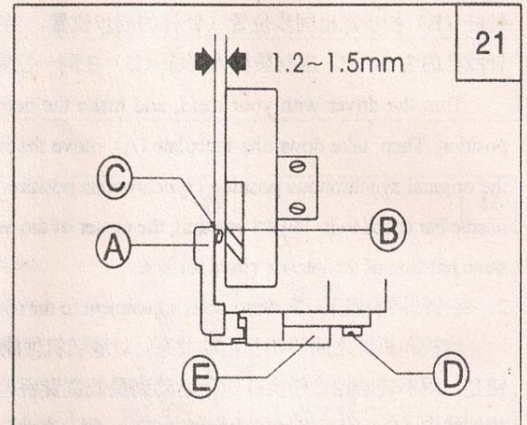

24. 送布牙安装三陵 (图 22、23)

24. Install feed dog (figure 22,23)

A、当送布量最大, 送布牙 (A) 前端靠近针板槽前时, 送布牙前端与针板槽前侧的间距为 1.5 毫米, 这是标准的送布牙安装位置。

When the feeding quantity is set the biggest, and the front end of the feed dog (A) is close to the front of the needle plate groove, the space between the front end of the feed dog and the front of the needle plate groove is 1.5mm-this is the standard installing position of the feed dog.

B、调节送布牙位置时, 先将送布运动至针板最前侧停止, 然后旋松送布轴曲柄螺钉 (A) (见图 29b), 将牙架 (B) 按图 29a 所示箭头方向移动, 以调节位置, 调节好后, 再把螺钉 (A) 旋紧。

When adjusting the position of the feed dog, move firstly the feed dog to the forefront of the needle plate, and then loosen the crank bolt (A) of the cloth-feeding shaft (see figure 29b). Move the teeth rest (B) in arrow direction shown in figure 29a to adjust the position. Fasten the bolt (A) after adjusting well.

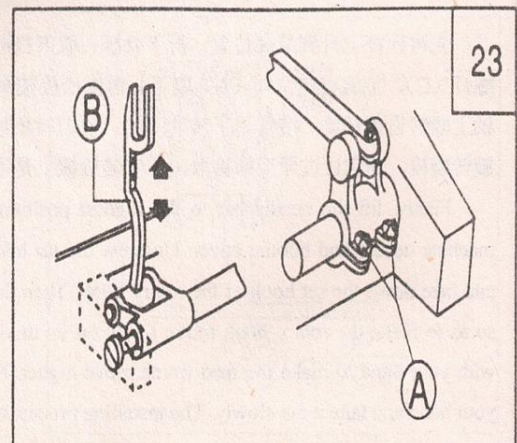
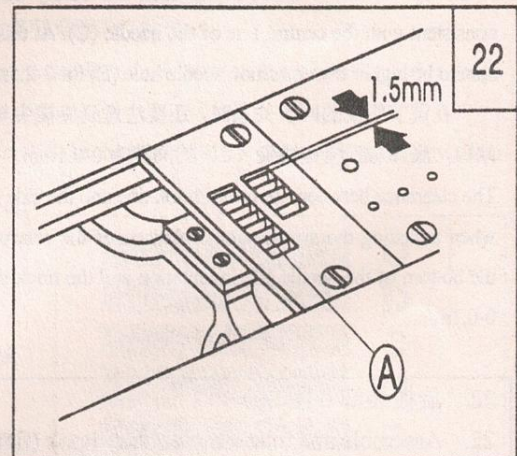

旋梭定位钩的安装位置应是旋梭定位钩 (A) 的钩槽侧面与梭心套头的侧面应成一致。另外其两侧面之间的间隙为 1.1-1.3 毫米。

The installing position of the set hook of the rotary hook is to make the groove side of the set hook (A) consistent with the side of the bobbin cover. Furthermore, the clearance between those two sides is 1.1-1.3mm.

23. 安装旋梭限位座 (图 21)

23. Install the spacing stop of the rotary hook (figure 21)

在安装旋梭限位座 E 时, 先拧紧螺钉 D。调整限位架与旋梭之间的距离为 1.2-1.5mm, 且限位簧头 C 与梭心套保持 1-1.2mm 距离的弹性, 这样才能让 C 头有弹性地限制住梭心套, 使之不脱落。还有, 不能让 C 头接触旋梭尖 B, 如相互碰到可以再适当调节旋梭限位座, 最后拧紧螺钉 D。

Fasten the bolt D firstly when installing the spacing stop of the rotary hook. Adjust and keep the distance between the spacing frame and the rotary hook 1.2-1.5mm, and the distance between the spacing spring C and the bobbin cover 1-1.2mm, thus make C limit the bobbin cover elastically without falling off. Furthermore, you can not allow C contact the rotary hook tine B. If they contact each other, you may adjust the spacing stop of the rotary hook. Finally, fasten the bolt D.

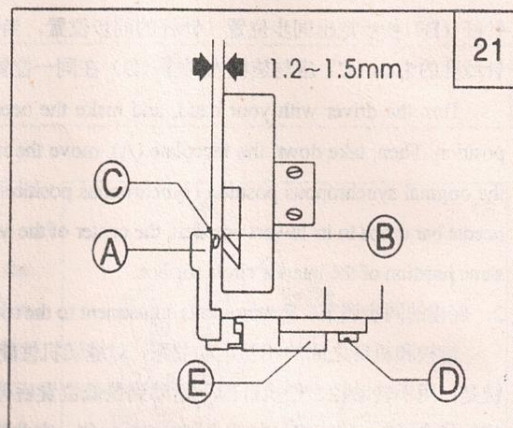

24. 送布牙安装三陵 (图 22、23)

24. Install feed dog (figure 22,23)

A、当送布量最大, 送布牙 (A) 前端靠近针板槽前时, 送布牙前端与针板槽前侧的间距为 1.5 毫米, 这是标准的送布牙安装位置。

When the feeding quantity is set the biggest, and the front end of the feed dog (A) is close to the front of the needle plate groove, the space between the front end of the feed dog and the front of the needle plate groove is 1.5mm-this is the standard installing position of the feed dog.

B、调节送布牙位置时, 先将送布运动至针板最前侧停止, 然后旋松送布轴曲柄螺钉 (A) (见图 29b), 将牙架 (B) 按图 29a 所示箭头方向移动, 以调节位置, 调节好后, 再把螺钉 (A) 旋紧。

When adjusting the position of the feed dog, move firstly the feed dog to the forefront of the needle plate, and then loosen the crank bolt (A) of the cloth-feeding shaft (see figure 29b). Move the teeth rest (B) in arrow direction shown in figure 29a to adjust the position. Fasten the bolt (A) after adjusting well.

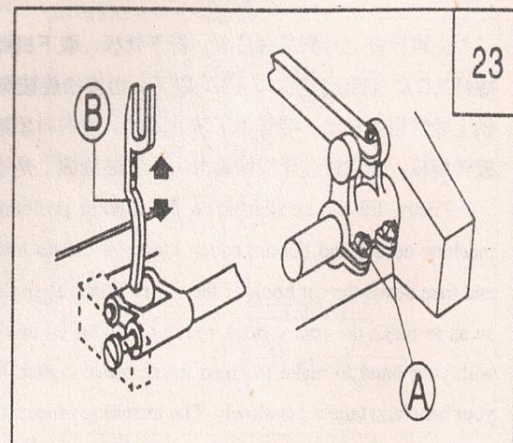
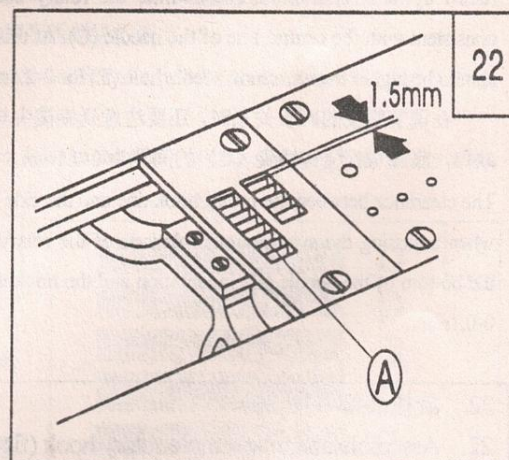

25. 送布同步调节 (图 24、25、26)

25. Synchronous adjustment to the cloth feeding (figure 24, 25, 26)

1、标准位置 Standard position

转动上轮,降低送布牙(A),当和针板表面(B)相平时,机针(C)的针尖应与针板,送布牙表面同在一水平面上。调整可以通过调节送布凸轮的安装位置进行。

Turn the upper shaft and lower the feed dog (A). The needlepoint of the machine needle (C) should be at the same level with the needle plate (B) and the feed dog surface when the feed dog flatly placed on the surface of the needle plate. Changing the installing position of the cloth-feeding cam can make the adjustment.

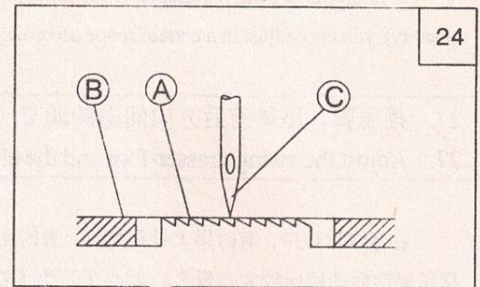

2、抬牙凸轮的安装 Install the feed lifting cam

打开上盖板,用手逆时针转动上轮,使机针上升到最高位置,此时抬牙凸轮的第一个螺钉(逆时针方向转的第一个螺丝)向逆时针方向偏45°,在此位置拧紧螺钉即可。

Open the upper cover board, and turn the upper shaft anticlockwise with your hand to make the needle move up to its highest position; meanwhile, turn the first bolt (the first bolt anticlockwise) of the feed lifting cam 45° anticlockwise, and fasten the bolt at this position.

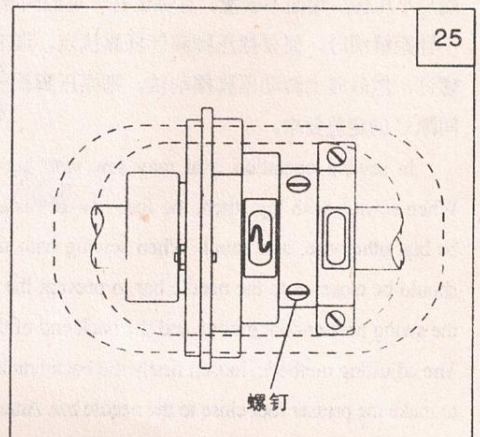

3、送布凸轮的安装

Install the cloth feeding cam

在抬牙凸轮安装好之后,再安装送布凸轮。以抬牙凸轮作为参照物,当机针抬到最高位置时,螺丝(A)向逆时针方向偏30°,也就是当抬牙凸轮的一个螺钉向顺时针方向偏15°。最后拧紧紧固套螺钉(B)。注意:螺丝(A)与另一螺丝不要弄错,它们的区别是另一螺丝有一个弹簧垫片。

Install the cloth-feeding cam after finishing the installation of the feed lifting cam. Referring to the feed-lifting cam, turn the bolt (A) 30° anticlockwise when the needle moving to its highest position. That is to say, turn the first bolt of the feed lifting cam 15° clockwise. Finally, fasten the binding bolt (B). Notice: The bolt (A) should be distinguished from the other bolt. The difference between them is that the other bolt has a spring cushion.

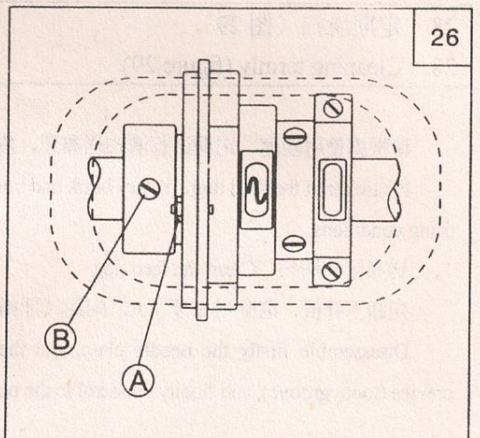

26. 上送料机构的调节 (图 27)

26. Adjust the upper feed mechanism (figure 27)

上下同步送料是该产品的重要性能之一。在缝纫过程中,应根据各种缝料的摩擦系数的不同和缝纫工艺的不同要求,对上送料机构的摆压脚滑块与摆压脚轴的中心距(L)进行调节。

Upper and lower feeding synchronously is one of the most important capabilities of the machine. In sewing operation, adjust the center distance (L) between the sliding blocks and the shaft of the swing presser-foot in upper feed mechanism.

调节方法:

Adjusting methods:

增大中心距 L-上送料量增大

Increase the center distance L-increase the quantity of the upper feeding.

减小中心距 L-上送料量减少。

Decrease the center distance L-decrease the quantity of the upper feeding.

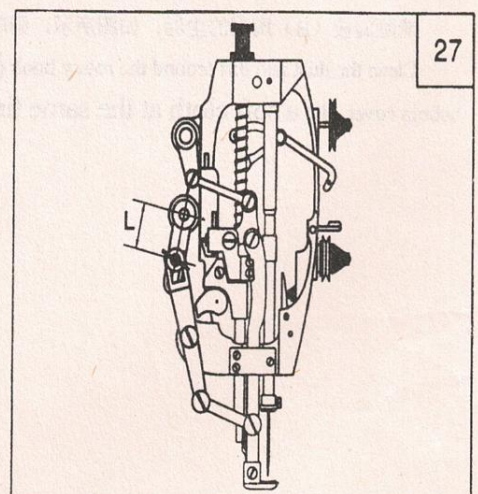

对于某些制品的特殊缝纫要求，如缝件的上层的上层的送料量要求大于（或小于）下层的料量，也可以根据以上原理在一定范围内调节使用。

As to special sewing requirements for some products (e.g. the upper feeding quantity required is bigger/smaller than the lower feeding quantity), you may adjust in a certain scope according to the theory mentioned above.

27. 摆压脚、压脚前后方向间隙的调节 (图 28)

27. Adjust the swing presser-foot and the clearance of the presser foot in front and back directions (figure 28)

在缝纫过程中，有时用大针距缝纫，有时用小针距缝纫，在大针距缝纫时，摆压脚前后动程比较大。反之，就小了。为了在缝纫过程中，使摆压脚槽的前端与小压脚后端面不会撞，且保证有一定的间隙C（一般取1.5mm左右）。放在小针距缝纫时，需要摆压脚向针杆靠拢点。调节方法：首先旋松摆压脚后曲柄螺钉，然后向上转动压脚摆动轴，则摆压脚就向针杆靠拢，调节时，应该注意间隙C的定值要求。

In sewing operation, you may sew with big stitch or small stitch sometimes. When sewing with big stitch, the fore-and-aft distance of the swing presser-foot will be big, otherwise, it is small. When sewing with small stitch, the swing presser-foot should be close up to the needle bar to prevent the collision between the front end of the swing presser-foot groove and the back end of the small presser foot and keep a clearance C between them (usually keep about 1.5mm). The adjusting methods: loosen firstly the back crank bolt of the swing presser-foot, and turn upward the swing shaft of the presser foot, so as to make the presser foot close to the needle bar. Attention should be paid to the value requirement of the clearance C when make adjustment.

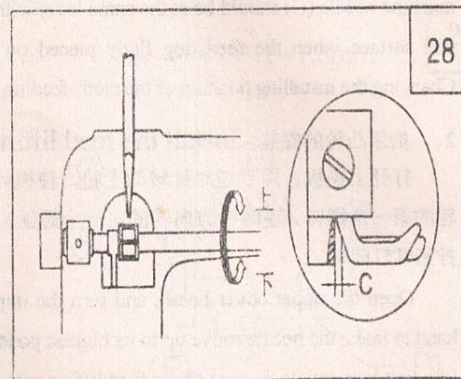

28. 定期清扫 (图 29)

28. Cleaning termly (figure 29)

请根据使用程度，定期进行清扫送布牙，旋梭、梭心套。

Please clean the feed dog, rotary hook and bobbin cover termly according to the using conditions.

1、送布牙的清扫 Clean the feed dog

先卸下针板，清除送布牙(A)间距(牙槽)内的法垢，然后再安好针板。

Disassemble firstly the needle plate, and then clean the dirt in feed dog (A) crevice (tooth groove), and finally reassemble the needle plate.

2、旋梭的清扫 Clean the rotary hook

清除旋梭(B)周围的尘垢，如图所示，同时用软布拭擦梭心套。

Clean the dust and dirt around the rotary hook (B) shown in figure, and wipe the bobbin cover with a soft cloth at the same time.

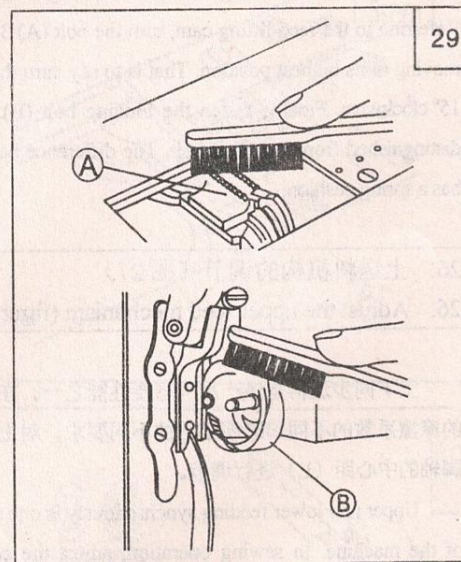

零件手册
PARTS MANUAL

1 机壳部分 Machine hull parts

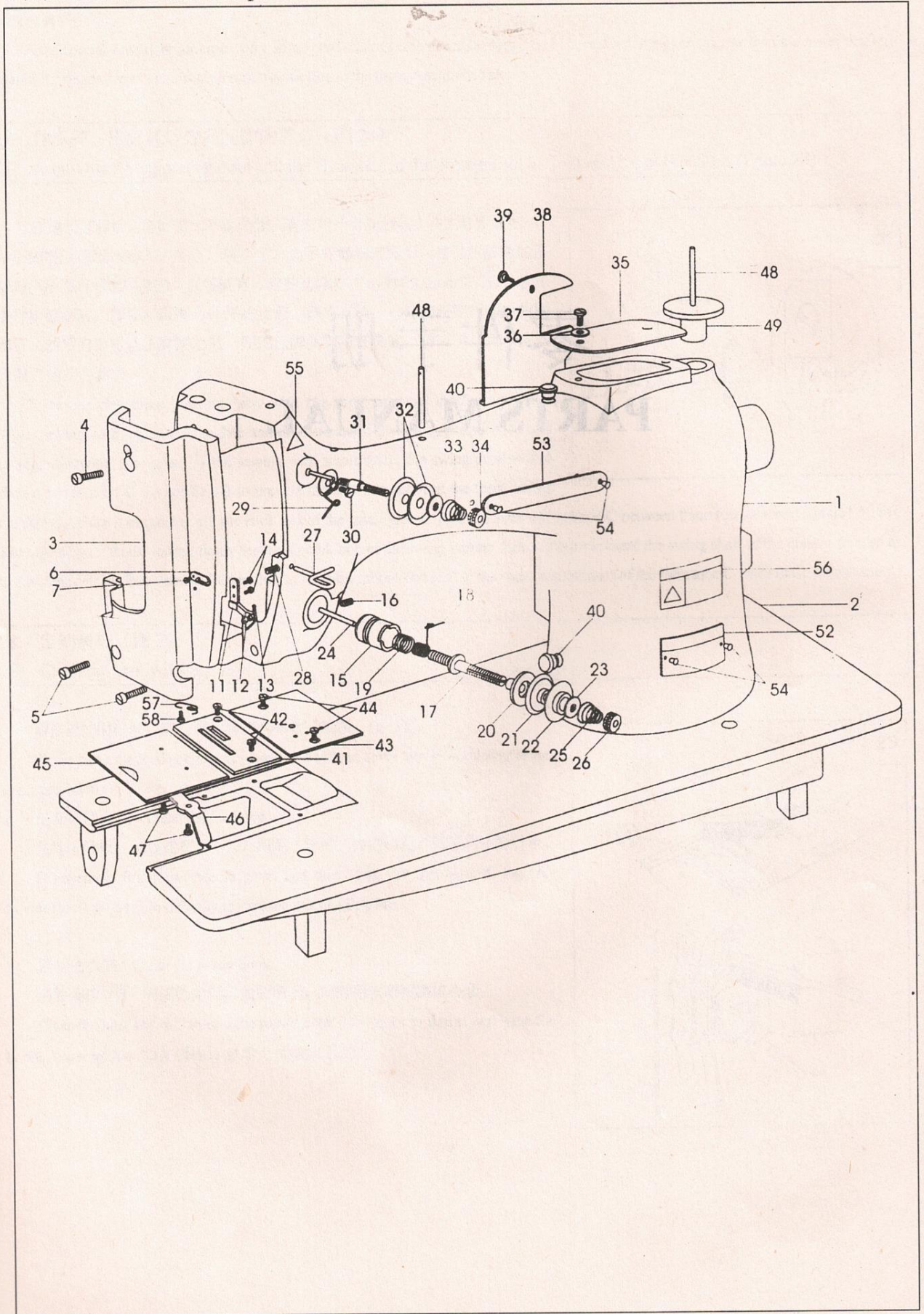

1 机壳部分 Machine hull parts

序号 Serial number	图号 Figure number	名称 Name	数量 Quantity	备注 Remarks
1	2541301	机壳 Hull	1	
2	2541302	平板 Flat plate	1	
3	2531303	面板 Face plate	1	
4	2531304	面板大螺钉 Big face plate bolt	1	
5	2531305	面板小螺钉 Small face plate bolt	2	
6	2531306	面板上线勾 Face plate upper thread hook	1	
7	2531307	上线勾螺钉 Upper thread hook bol	1	
11	2531311	过线架 Thread take-up eyelet holder	1	
12	2531312	过线套 Thread take-up eyelet cover	1	
13	2531313	紧固螺钉 Fastening bolt	1	
14	2531314	过线架螺钉 Thread take-up eyelet holder bolt	2	
15	2531315	夹线座 Thread course tension jack	1	
16	2531316	夹线座紧固螺钉 Fastening bolt of thread course tension jack	1	
17	2531317	夹线钉 Thread course tension screw	1	
18	2531318	挑线弹簧 Thread take-up spring	1	
19	2531319	调节弹簧 Adjusting spring	1	
20	2531320	调节盘 Adjusting disk	1	
21	2531321	夹线板(内) Thread course tension disk (inner)	1	
22	2531322	夹线板(外) Thread course tension disk (outer)	1	
23	2531323	松线板 Thread course loosen disk	1	
24	2531324	松线钉 Thread course loosen screw	1	
25	2531325	夹线弹簧 Thread course tension spring	2	
26	2531326	夹线螺母 Thread course tension nut	1	
27	2531327	下线勾 Lower thread hook	1	
28	2531328	下线勾紧固螺钉 Fastening bolt of lower thread hook	1	
29	2531329	上线勾 Upper thread hook	1	
30	2531330	上线勾紧固螺钉 Fastening bolt of upper thread hook	1	
31	2531331	夹线钉 Thread course tension screw	1	
32	2531332	夹线板 Thread course tension disk	2	
33	2531333	夹线弹簧 Thread course tension spring	1	
34	2531334	夹线螺母 Thread course tension nut	1	
35	2531335	上盖板 Upper cover board	1	
36	2531336	垫片 Cushion	1	
37	2531337	上盖板螺钉 Upper cover board bolt	1	
38	2531338	后盖板 Back cover board	1	
39	2531339	后盖板螺钉 Back cover board bolt	1	
40	2531340	橡皮塞 Rubber plug	2	
41	2531341	针板 Needle plate	1	
	2541341	防漏条针板 Needle plate		选用
42	2531342	针板螺钉 Needle plate bolt	2	
43	2531343	右推板 Right pushing board	1	
44	2531344	右推板螺钉 Right pushing board bolt	2	
45	2531345	左推板 Left pushing board	1	
46	2531346	板簧 Board spring	1	
47	2531347	左推板螺钉 Left pushing board bolt	2	
48	2531348	过线钉 Thread take-up screw	2	
49	2531349	过线钉座 Thread take-up screw jack	1	
52	2541352	机号牌 Machine serial number nameplate	1	
53	2531353	商标牌 Brand nameplate		
54		标牌铆钉 Scutcheon rivet	4	
55	2531355	危险三角标志 Triangle symbol DANGER	1	
56		警示牌 Caution signs	1	
57	2531357	弹簧过线架 Spring thread take-up eyelet holder	1	
58	2531358	螺钉 Bolt	1	

2 挑线勾线部分 Thread take-up and thread hooking parts

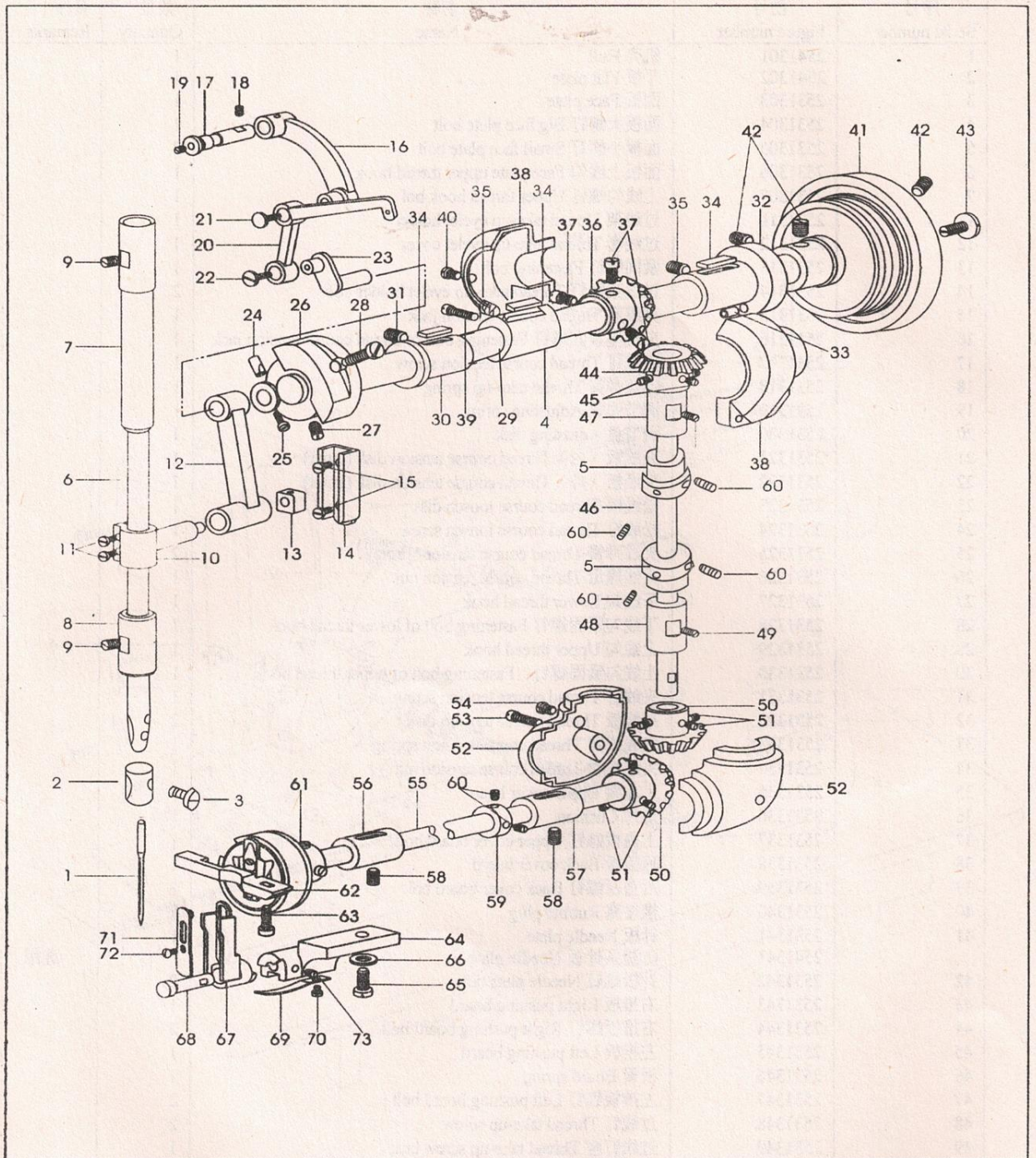

2. 挑线勾线部分 Thread take-up and thread hooking parts

序号 Serial number	图号 Figure number	名称 Name	数量 Quantity	备注 Remarks
1		机针 Machine needle	1	
2	2531502	针夹 Needle clamp	1	
3	2531503	夹针螺钉 Needle clamp bolt	1	
4	2541574	上轴中轴套 Center axle sleeve fer upper shaft	1	
5	2541575	坚轴紧圈 packing ring	1	
6	2531506	针杆 Iron bar	1	
7	2531507	针杆上套 Iron bar upper cover	1	
8	2531508	针杆下套 Iron bar lower cover	1	
9	2531509	针杆套筒螺钉 Iron bar sleeve bolt	2	
10	2531510	针杆接头 Iron bar tie-in	1	

11	2531511	针杆接头紧固螺钉 Fastening bolt for iron bar tie-in	2
12	2531512	针杆连杆 Iron bar connecting bar	1
13	2531513	滑块 Slider	1
14	2531514	滑块槽 Slider groove	1
15	2531515	滑块槽螺钉 Slider groove bolt	2
16	2531516	挑线连杆 Take-up thread connecting bar	1
17	2531517	挑线连杆销 Connecting bar pin of take-up thread	1
18	2531518	挑线连杆销紧固螺钉 Fastening bolt for take-up thread bar pin	1
19	2531519	连杆销螺钉 Bolt of connecting bar pin	1
20	2531520	挑线杆 Thread take-up lever	1
21	2531521	连接钉 Connecting bolt	1
22	2531522	挑线杆螺钉 Thread take-up lever bolt	1
23	2531523	挑线曲柄 Take-up thread crank	1
24	2531524	挑线曲柄定向柱 Directional pillar of take-up thread crank	1
25	2531525	挑线曲柄螺钉 Bolt of take-up thread crank	1
26	2531526	针杆曲柄 Needle bar crank	1
27	2531527	针杆曲柄紧固螺钉 Fastening bolt for needle bar crank	1
28	2531528	针杆曲柄定位螺钉 Set bolt for needle bar crank	1
29	2541529	上轴 Upper shaft	1
30	2541530	上轴前轴套 Front axle sleeve for upper shaft	1
31	2531531	前轴套螺钉 Front axle sleeve bolt	1
32	2531532	上轴后轴套 Back axle sleeve for upper shaft	1
33	2531533	后轴套油管 Oil tube of back axle sleeve	1
34	2531534	毛毡 Woolfelt	3
35	2531535	螺钉 Bolt	2
36	2531536	上轴伞齿轮 Upper shaft bevel gear	1
37	2531537	上轴伞齿轮螺钉 Bolt of upper shaft bevel gear	3
38	2531538	上伞齿轮油罩 Oil shield of upper shaft bevel gear	1
39	2531539	紧固螺钉 Fastening bolt	1
40	2531540	螺钉 Bolt	1
41	2531541	上轮 Upper wheel	1
42	2531542	上轮螺钉 Upper wheel bolt	3
43	2531543	上轮吊紧螺钉 Set bolt for upper wheel	1
44	2531544	竖轴上伞齿轮 Vertical axis upper bevel gear	1
45	2531545	伞齿轮螺钉 Bevel gear bolt	3
46	2531546	竖轴 Vertical axis	1
47	2531547	竖轴上套 Vertical axis upper cover	1
48	2531548	竖轴下套 Vertical axis lower cover	1
49	2531549	套筒紧固螺钉 Sleeve fastening bolt	2
50	2531550	下伞齿轮 Lower bevel gear	2
51	2531551	螺钉 Bolt	6
52	2531552	下伞齿轮油罩 Oil shield for lower bevel gear	1
53	2531553	紧固螺钉 Fastening bolt	1
54	2531554	螺钉 Bolt	1
55	2541555	下轴 Lower shaft	1
56	2541556	下轴前轴套 Lower shaft front axle cover	1
57	2531557	下轴后轴套 Lower shaft back axle cover	2
58	2531558	螺钉 Bolt	1
59	2531559	紧圈 Packing ring	1
60	2531560	紧圈螺钉 Packing ring bolt	6
61	2531561	旋梭组件 Rotating hook subassembly	1
62	2531562	旋梭定位钩 Directional hook of rotating hook	1
63	2531563	旋梭定位钩螺钉 Directional hook bolt of rotating hook	1
64	2531564	限位座 Spacer assembly	1
65	2531565	限位座螺钉 Spacer assembly bolt	1
66		垫圈 Washer	1
67	2531567	限位架 Spacer	1
68	2531568	限位架轴 Spacer shaft	1
69	2531569	板簧 Plate spring	1
70	2531570	板簧螺钉 Plate spring bolt	1
71	2531571	限位簧 Spacer spring	1
72	2531572	限位簧螺钉 Spacer spring bolt	1
73	2531573	限位架轴螺钉 Spacer shaft bolt	1

3. 下送料部件 Lower feed parts

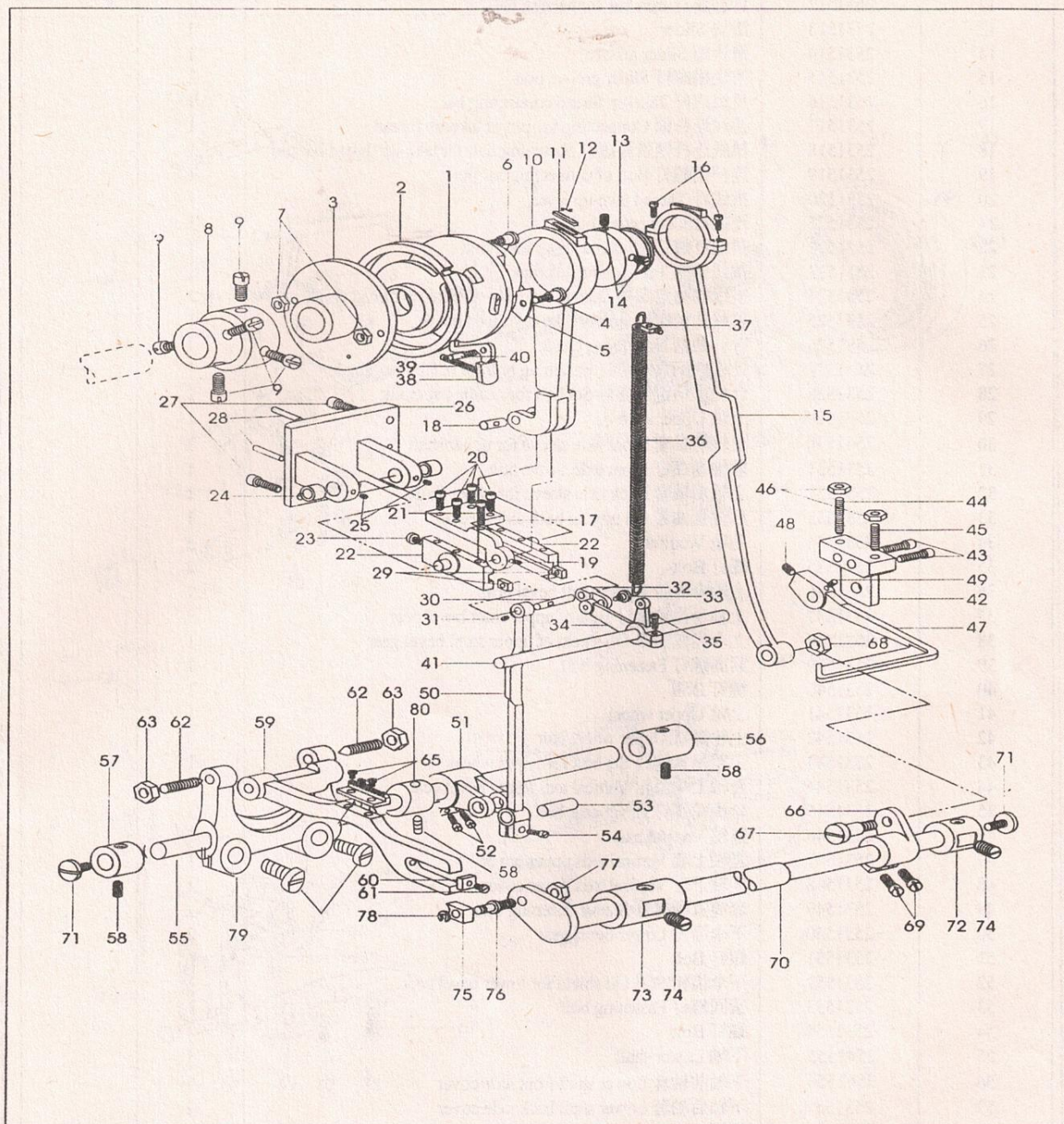

3. 下送料部件 Lower feed parts

序号 Serial number	图号 Figure number	名称 Name	数量 Quantity	备注 Remarks
1	2531701	送布凸轮 Cloth feeding cam	1	
2	2531702	偏心调节盘 Eccentric adjusting disk	1	
3	2531703	偏心定位盘 Eccentric spacer disk	1	
4	2531704	螺钉 Bolt	1	
5	2531705	垫片 Cushion	1	
6	2531706	螺钉 Bolt	1	
7	2531707	螺母 Nut	2	
8	2531708	送布凸轮定位套 Spacer cover of cloth feeding cam	1	
9	2531709	定位套螺钉 Spacer cover bolt	5	
10	2531710	送布大连杆 Cloth feeding big end	1	
11	2531711	油毡 Tarred felt	1	
12	2531712	定位簧 Spacer spring	1	
13	2531713	抬牙凸轮 Tooth lifting cam	1	
14	2531714	抬牙凸轮螺钉 Tooth lifting cam bolt	2	

15	2531715	拾牙大连杆 Tooth-lift big end	1
16	2531716	大连杆螺钉 Big end bolt	2
17	2531717	送布连接块 Connecting block of cloth feeding	1
18	2531718	连接销 Connecting pin	1
19	2531719	连接销螺钉 Connecting pin bolt	1
20	2531720	连接块紧固螺钉 (短) Fastening bolt of connecting block (short)	4
21	2531721	连接块紧固螺钉 (长) Fastening bolt of connecting block (long)	1
22	2531722	滑块摇板 Slider swing plate	2
23	2531723	滑块限位螺钉 Slider spacing bolt	2
24		滚针轴承 Needle roller bearing	2
25	2531725	轴承紧固螺钉 Bearing fastening bolt	2
26	2531726	摇板座 Swing plate assembly	1
27	2531727	摇板座螺钉 Swing plate assembly bolt	3
28		锥销 Cone pin	2
29	2531729	滑块 Slider	2
30	2531730	滑块销轴 Slider bearing pin	1
31	2531731	惰轴紧固螺钉 Fastening bolt of bearing pin	1
32	2531732	倒顺小连杆 Small forward-reverse connecting bar	1
33	2531733	连杆螺钉 Connecting bar bolt	1
34	2531734	倒顺大连杆 Big forward-reverse connecting bar	1
35	2531735	紧固螺钉 Fastening bolt	1
36	2531736	倒顺弹簧 Forward-reverse spring	1
37	2531737	弹簧定位销钉 Spring spacing pin	1
38	2531738	针距调节扳手 Stitch space adjusting spanner	1
39	2531739	弹簧 Spring	1
40	2531740	扳手定位螺钉 Spanner spacing bolt	1
41	2531741	倒顺轴 Forward-reverse axle	1
42	2531742	倒顺扳手限位架 Forward-reverse spanner spacing frame	1
43	2531743	限位架螺钉 Spacing frame bolt	2
44	2531744	限位调节螺钉 (长) Space adjusting bolt (long)	1
45	2531745	限位调节螺钉 (短) Space adjusting bolt (short)	1
46	2531746	螺母 Nut	2
47	2531747	扳手 Spanner	1
48	2531748	螺钉 Bolt	1
49	2531749	螺钉 Bolt	1
50	2531750	送布连杆 Cloth-feed connecting bar	1
51	2531751	送布曲柄 Cloth-feed crank	1
52	2531752	曲柄紧固螺钉 Crank fastening bolt	2
53	2531753	销轴 Bearing pin	1
54	2531754	紧固螺钉 Fastening bolt	1
55	2531755	送布轴 Cloth-feed axle	1
56	2531756	送布轴后套 Back cover of cloth-feed axle	1
57	2531757	送布轴前套 Front cover of cloth-feed axle	1
58	2531758	螺钉 Bolt	2
59	2531759	牙架 Feed bar	1
60		毛毡 Woolfelt	1
61	2531761	螺钉 Bolt	1
62	2531762	牙架顶尖螺钉 Pointed bolt at the top of feed bar	2
63	2531763	牙架顶尖螺母 Pointed nut at the top of feed bar	2
64	2531764	送布牙 Throat plate	1
65	2531765	送布牙螺钉 Throat plate bolt	2
66	2531766	拾牙曲柄 Tooth lifting crank	1
67	2531767	连接螺钉 Connecting bolt	1
68	2531768	螺母 Nut	1
69	2531769	曲柄紧固螺钉 Crank fastening bolt	2
70	2531770	拾牙轴 Tooth-lift axle	1
71	2531771	拾牙轴吊紧螺钉 Set bolt of tooth-lift axle	2
72	2531772	拾牙轴后套 Tooth-lift axle back cover	1
73	2531773	拾牙轴前套 Tooth-lift axle front cover	1
74	2531774	套筒螺钉 Sleeve bolt	2
75	2531775	拾牙滑块 Tooth-lift slider	1
76	2531776	滑块螺钉 Slider bolt	1
77	2531777	螺母 Nut	1
78		开口挡圈 Open-end gasket	1
79	18001706	牙架座 Feed connection Crank	1
80	2541780	送布轴中套 Center cover of cloth-feed axle	1

4. 拉杆压杆部件 Tie rod and press rod parts

序号 Serial number	图号 Figure number	名称 Name	数量 Quantity	备注 Remarks
1	2531901	拉杆 Tie rod	1	
2	2541902	连接器 Adjusting Rod	1	
3	2541903	连接螺母 Nut	2	
4	2531904	连接螺钉 Tie-in bolt	1	
5	2531905	杠杆拉杆 Lever tie rod	1	
	253A1905	杠杆拉杆 Lever tie rod	1	
6	2531906	杠杆提升销 Lever lifting pin	1	
7	2531907	螺钉 Bolt	1	
8	2531908	杠杆弹簧 Lever spring	1	
9	2531909	弹簧定位销 Spring register pin	1	
10	2531910	杠杆螺钉 Lever bolt	1	
11	2531911	调压螺钉 Pressure adjusting bolt	1	
12	2531912	调压螺母 Pressure adjusting nut	1	
13	2531913	调压弹簧 Pressure adjusting spring	1	
14	2531914	压紧杆 Compressor arm	1	
15	2531915	压杆平导架 Press rod flat-guide stand	1	
16	2531916	平导架螺钉 Flat-guide stand bolt	2	
17	2531917	平导架限位块 Flat-guide stand stop block	1	
18	2531918	螺钉 Bolt	1	
19	2531919	锁紧螺母 Lock nut	1	
20	2531920	压杆弯导架 Press rod curly-guide stand	1	
21	2531921	挂钩 Pothook	1	
22	2531922	螺钉 Bolt	1	
23	2531923	导向定位座 Guided register	1	
24	2531924	定位座螺钉 Register bolt	2	
25	2531925	抬压凸轮 Presser-lifting cam	1	
26	2531926	抬压扳手 Presser-lifting spanner	1	
27		锥销 Cone pin	1	GB117-86 A3×12
28	2531928	小压脚 Small presser foot	1	
	2541928	防漏条压脚 Small presser foot		选用
29	2531929	防护架 Guard stand	1	
30		垫圈 Washer	1	GB97.1-85-5
31	2531931	小压脚螺钉 Small presser foot bolt	1	
32	2531932	挺线勾 Erect thread hook	1	
33	2531933	挺线弹簧 Erect thread spring	1	
34	2531934	挺线勾定位螺钉 Register bolt of erect thread	1	
35	2541935	膝动杆 Knee Lifter Crank(Rear)	1	
36	2541936	膝动滚柱 Roller	1	
37	2541937	膝动螺钉 Hinge Screw	1	
38	251938	连接器固定螺钉 Screw	1	
39	2541939	抗压螺钉 Hinge Screw	1	

5 上送料部件 Upper feed parts

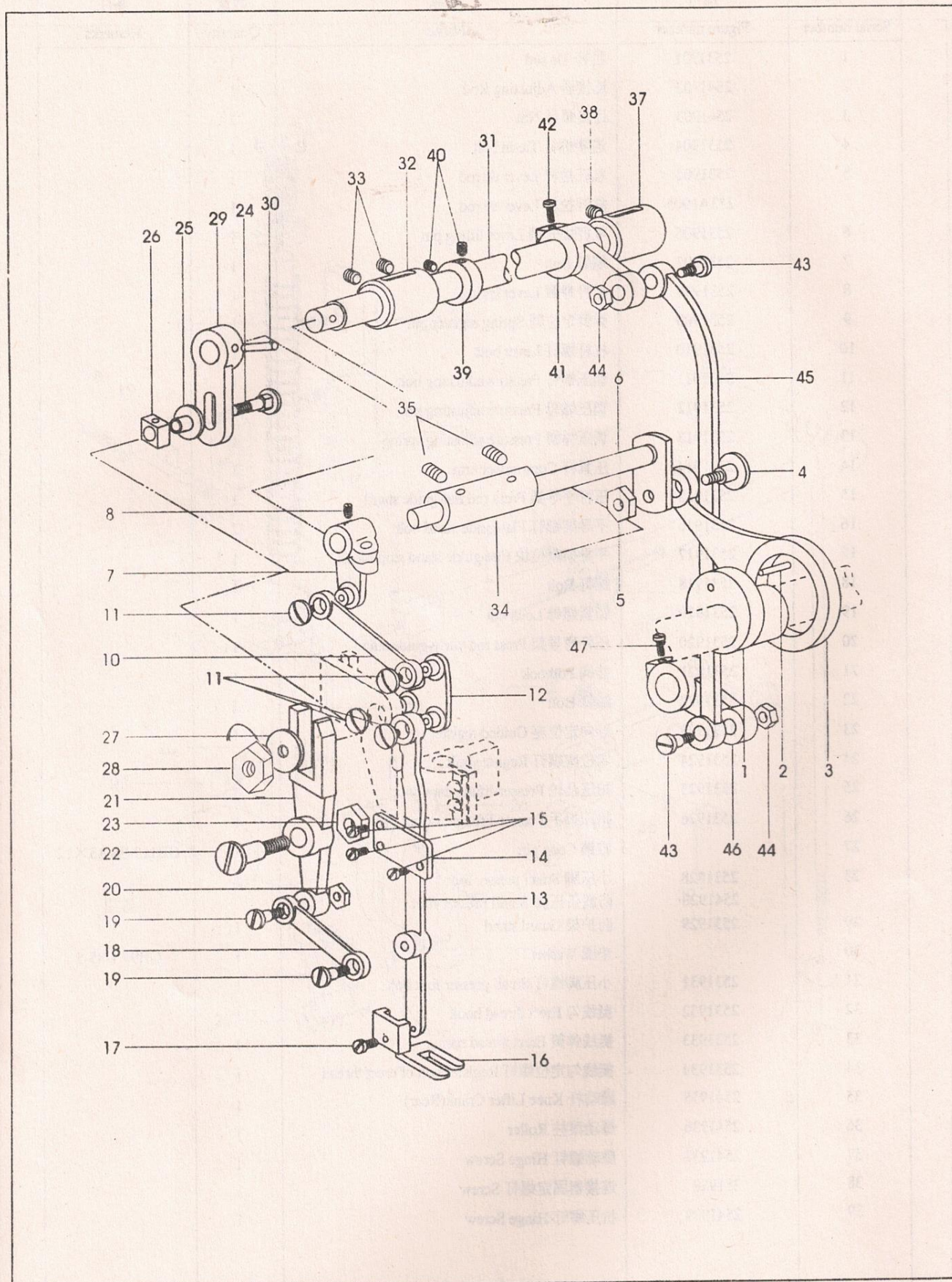

5. 上送料部件 Upper feed parts

序号 Serial number	图号 Figure number	名称 Name	数量 Quantity	备注 Remarks
1	2532101	压脚升降凸轮 Presser foot lift cam	1	
2	2532102	销 Pin	1	
3	2532103	压脚升降大连杆 Presser foot lift big end	1	
4	2532104	大连杆螺钉 Big end bolt	1	
5	2532105	螺母 Nut	1	
6	2532106	压脚升降轴 Presser foot lift bearing	1	
7	2542107	压脚升降曲柄 Presser foot lift crank	1	
8	2532108	曲柄螺钉 Crank bolt	1	
10	2532110	小连杆 Small connecting rod	1	
11	2532111	螺钉 Bolt	4	
12	2532112	压脚升降摇板 Presser foot lift rocking plate	1	
13	2532113	摆压脚杆 Swing presser foot rod	1	
14	2532114	压脚杆导板 Presser foot rod guide plate	1	
15	2532115	导板螺钉 Guide plate bolt	3	
16	2542116	大压脚 Big presser foot	1	
17	2532117	大压脚螺钉 Big presser foot bolt	1	
18	2532118	摆压脚连杆 Swing presser foot connecting rod	1	
19	2532119	连杆螺钉 Connecting rod bolt	2	
20	2532120	连杆螺母 Connecting rod nut	1	
21	2532121	摆压脚叉型杆 Swing presser foot furcated rod	1	
22	2532122	叉型杆固定螺钉 Furcated rod set bolt	1	
23	2532123	螺母 Nut	1	
24	2532124	叉型杆连接螺钉 Furcated rod connecting bolt	1	
25	2532125	衬套 Bush	1	
26	2532126	滑块 Sliding block	1	
27	2532127	垫片 Washer	1	
28	2532128	螺母 Nut	1	
29	2532129	摆动轴前曲柄 wing axle front crank	1	
30		锥销 Cone pin	1	
31	2532131	摆动轴 Swing axle	1	
32	2532132	摆动轴前套 Swing axle front cover	1	
33	2532133	螺钉 Bolt	2	
34	2542134	轴套 Axle	1	
35	2542135	紧固螺钉 Fastening bolt	2	
37	2532137	摆动轴后套 Swing axle back cover	1	
38	2532138	螺钉 Bolt	1	
39	2532139	摆动轴紧圈 Swing axle set collar	1	
40	2532140	螺钉 Bolt	2	
41	2532141	摆动轴后曲柄 Swing axle back crank	1	
42	2532142	螺钉 Bolt	1	
43	2532143	连接螺钉 Connecting bolt	2	
44	2532144	连接螺母 Connecting nut	2	
45	2532145	摆动大连杆 Swing big end	1	
46	2532146	摆动轴下曲柄 Swing axle lower crank	1	
47	2532147	紧固螺钉 Fastening bolt	1	

6 膝动部件 Knee lifter components

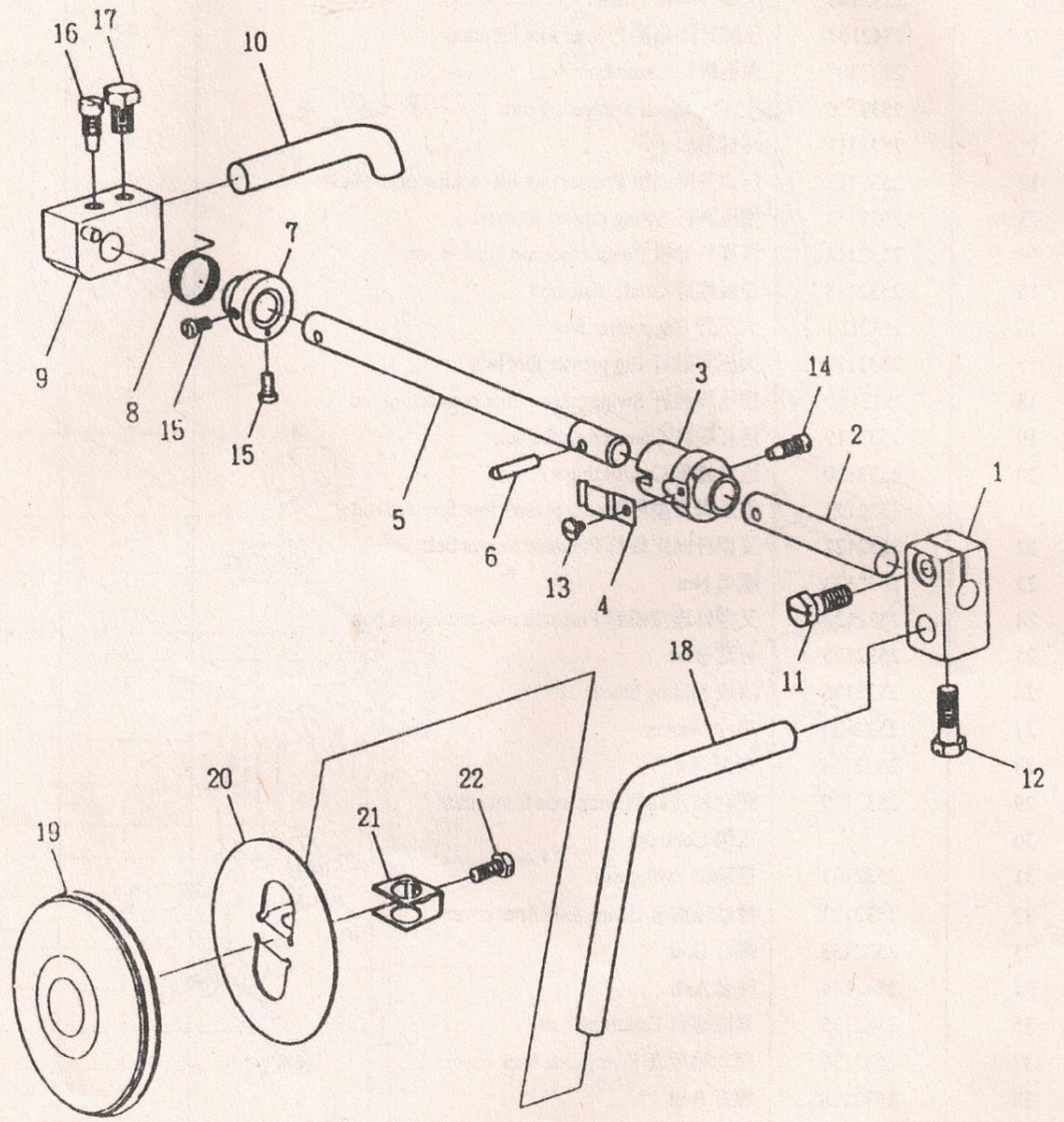

6 膝动部件 Knee lifter components

序号 Serial number	图号 Figure number	名称 Name	数量 Quantity	备注 Remarks
1	2542301	连接器 Kndd Lifter Crand(Front)	1	
2	2542302	连接杆 Knee Lifter Coupling Shaft	1	
3	2542303	连接器 Knee Lifter Coupling	1	
4	2542304	连接弹簧 Spring Plate	1	
5	2542305	膝动直杆 Knee Lifter Shaft	1	
6	2542306	固定销 Pin	1	
7	2542307	弹簧支板 Retaining Plate	1	
8	2542308	弹簧 Spring	1	
9	2542309	连接器(组) Knee Lever Rod Asm.	1	
10	2542310	膝动曲杆 Knee Lever Rod	1	
11	2542311	连接器固定螺钉 Screw	1	
12	2542312	曲杆固定螺钉 Screw	1	
13	2542313	弹簧固定螺钉 Screw	1	
14	2542314	支板固定螺钉 Screw	1	
15	2542315	支板固定螺钉 Screw	2	
16	2542316	曲杆固定螺钉 Screw	1	
17	2542317	曲杆固定螺钉 Screw	1	
18	2542318	膝压曲杆 Knee Lever Rod	1	
19	2542319	膝动柄 Knee Gurd	1	
20	2542320	膝动柄支架 Knee Plate	1	
21	2542321	膝动柄固定支架 Retainer	1	
22	2542322	膝动柄固定螺钉 Screw	1	

7 气缸部件(254A) Puller cylinder parts

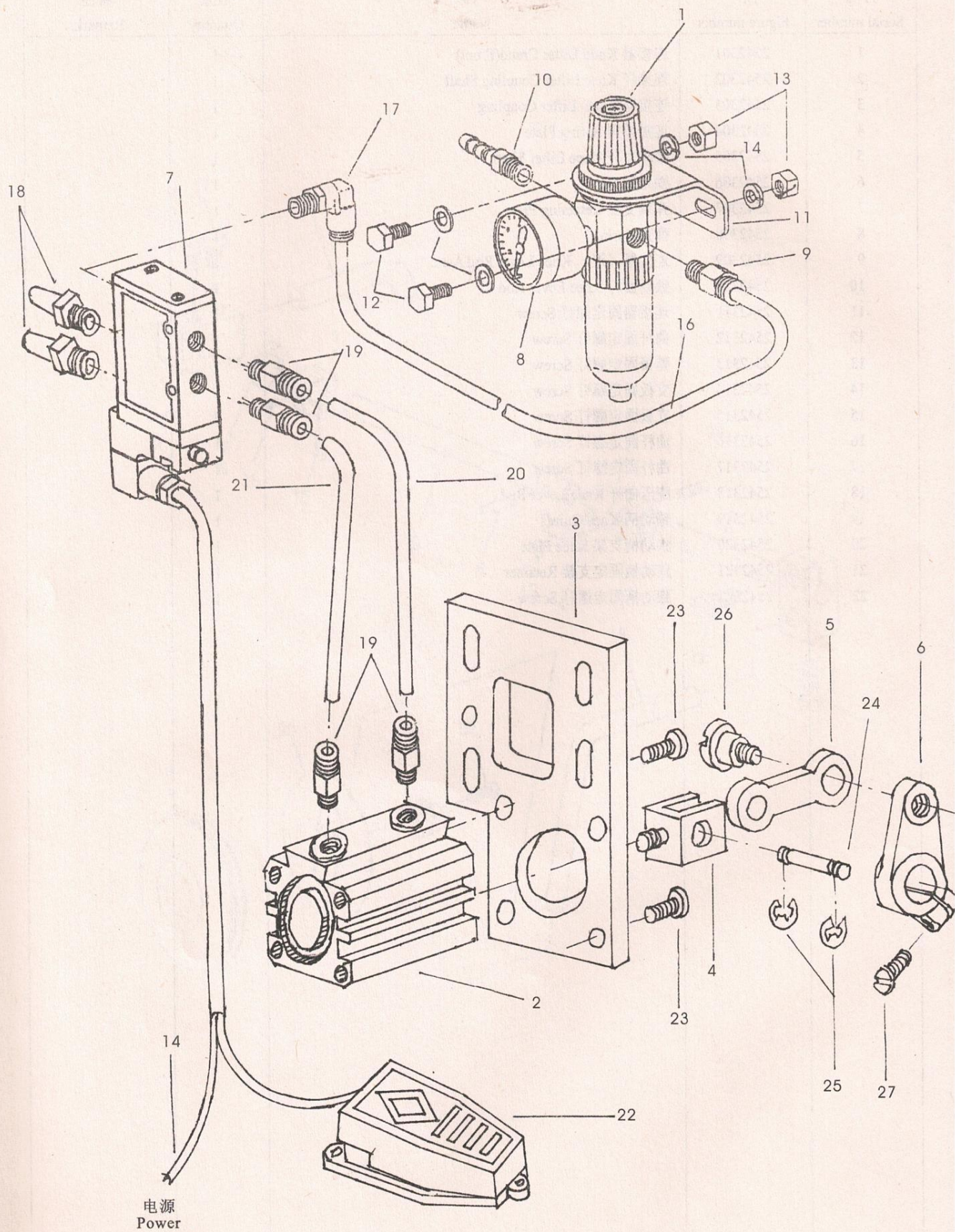

7 气缸部件(254A) Puller cylinder parts

序号 Serial number	图号 Figure number	名称 Name	数量 Quantity	备注 Remarks
1	254A2301	调压过滤网 Regulator	1	
2	254A2302	气缸 Puller cylinder	1	
3	254A2303	气缸座 Puller cylinder bracket	1	
4	254A2304	气缸连接器 Knuckle	1	
5	254A2305	连杆 Upper feed link	1	
6	254A2306	侧顺曲柄 Small forward-reverse connecting bar	1	
7	254A2307	电磁阀 Solenoid valve	1	
8	254A2308	压力表 Pressure gauge	1	
9	254A2309	管接头 Joint	1	
10	254A2310	管接头 Joint	1	
11	254A2311	过滤器支架 Regulator bracket	1	
12	254A2312	螺钉 Screw	2	
13	254A2313	螺母 Nut	2	
14	254A2314	弹簧垫 Spring washer	2	
15	254A2315	垫圈 Washer	2	
16	254A2316	汽管 Air tube	1	
17	254A2317	管接头 (90°) Joint (90°)	1	
18	254A2318	消声器 Silencer	2	
19	254A2319	管接头 Joint (straight)	4	
20	254A2320	汽管 Air tube	1	
21	254A2321	汽管 Air tube	1	
22	254A2322	脚踏开关 Foot switch	1	
23	254A2323	螺钉 Screw	4	
24	254A2324	销轴 Bearing pin	1	
25	254A2325	开口挡圈 Open-end gasket	2	
26	254A2326	连杆螺钉 Connecting bolt	1	
27	254A2327	螺钉 Screw	1	

8. 附件 Accessories

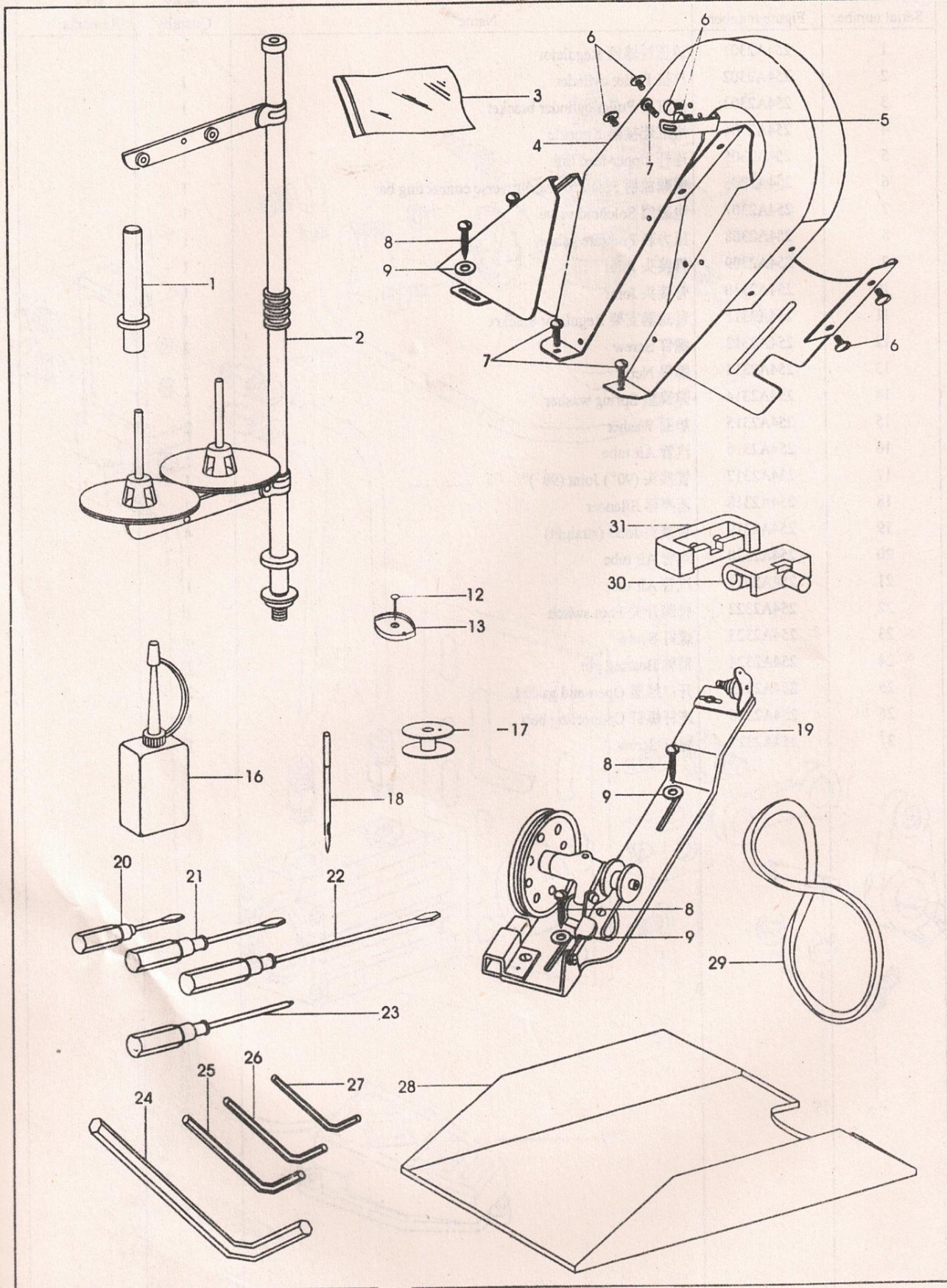

8. 附件 Accessories

序号 Serial number	图号 Figure number	名称 Name	数量 Quantity	备注 Remarks
1		机头撑杆 Machine head strut bar	1	
2	2532301	线架组件 Line frame subassembly	1	
3	2532303	零件袋 Parts bag	2	
4	2532304	防护罩 Shield	1	
5	2532305	防护罩定位架 Shield spacer	1	
6	2532306	防护罩螺钉 Shield bolt	6	
7	2532307	防护罩定位螺钉 Shield set bolt	3	
8		自攻螺钉 Tapping screw	4	GB5282-85ST4.8×19
9		自攻螺钉垫圈 Tapping screw washer	4	GB848-85-6
12		油盘固定钉 Oil tray set nail	8	Nail length22mm
13	2532313	机头防震垫块 Head quakeproof cushion	4	
16	2532316	油壶 Oil can	1	
17	2532317	梭芯 Bobbin core	6	
18		机针 Machine needle	3	DD×1 25#-27#
19	2532319	绕线器组件 Bobbin winder subassembly	1	
20	2312320	一字槽开刀(小)“-”Groove screwdriver (small)	1	
21	2532321	一字槽开刀(中)“-”Groove screwdriver (middle)	1	
22	2532322	一字槽开刀(大)“-”Groove screwdriver (big)	1	
23	2532323	十字槽开刀“+”Groove screwdriver	1	
24		内六角扳手 Inner-hexagon spanner	1	S=5
25		内六角扳手 Inner-hexagon spanner	1	S=3
26		内六角扳手 Inner-hexagon spanner	1	S=2.5
27	2532327	内六角扳手 Inner-hexagon spanner	1	S=2
28	2542328	油盘 Oil can	1	
29	2532329	elt	1	
30	2532330	机壳铰链 Machine hull gemel	2	
31		机壳铰链套 Machine hull gemel cover	2	