



0303D

**DIRECT-DRIVE AUTO-LUBRICATION UPPER &
LOWER FEED LOCKSTITCH SEWING MACHINE**

0303DCX

**DIRECT-DRIVE AUTO-LUBRICATION UPPER & LOWER FEED
LOCKSTITCH SEWING MACHINE WITH THICK THREAD**

OPERATION INSTRUCTION / PARTS MANUAL

Please don't adjust and repair the machine by non-professionals,except adjusting stitch.

Specifications subject to change without notice

CONTENTS

Operation Instruction

1、 Brief introduction.....	1
2、 Machine specification.....	1
3、 Installing the oil pan and safety switch magnet.....	1
4、 Installing the machine head.....	2
5、 Installing the knee lifter assy.....	2
6、 Adjusting the knee lifter.....	3
7、 Lubrication.....	3
8、 Test operation.....	4
9、 Installing the needle.....	5
10、 Removing the bobbin case.....	5
11、 Winding the bobbin thread.....	5
12、 Threading the bobbin thread.....	6
13、 Threading the needle thread.....	6
14、 Adjusting the stitch length.....	7
15、 Sewing and backtacking.....	7
16、 Adjusting the thread tension.....	8
17、 Adjusting the presser foot pressure.....	8
18、 Adjusting the thread tension spring.....	9
19、 Adjusting the upper thread guide.....	10
20、 Adjusting the presser foot height.....	10
21、 Adjusting the feed dog height.....	10
22、 Adjusting the feed dog angle.....	11
23、 Adjusting the difference of stitch length between the forward and backtacking.....	11
24、 Adjusting the tension release.....	11
25、 Adjusting the timing of needle and feed mechanism.....	12
26、 Adjusting the rotary hook lubrication amount.....	12
27、 Adjusting the height of needle bar and the timing with hook.....	13
28、 Adjusting the oil pump.....	13
29、 Adjusting the lifting amount of presser feet.....	16 ~ 17
30、 Needle bar and thread take-up mechanism.....	18 ~ 19
31、 Clean	
3、 Presser foot mechanism.....	20 ~ 21
4、 Feed mechanism.....	22 ~ 25
5、 Upper feed mechanism.....	26 ~ 27
6、 Hook mechanism.....	28 ~ 29
7、 Lubrication mechanism.....	30 ~ 31
8、 Accessories.....	32 ~ 33

Operation Instruction

1. Brief introduction

This machine is designed with link type feed mechanism and link lever thread take-up mechanism and full lubrication by pump. It's suitable for sewing leather, canvas and other heavy weight materials, such as suitcase, car seat, tent, sofa, etc.

2. Main specifications

Model	GC0303D	GC0303DCX
Applications	Medium & heavy weight materials	
Max sewing speed	2000 s.p.m	1800 s.p.m
Max stitch length	8mm	12mm
Needle bar stroke	37mm	
Lifting amount of presser feet	3.5-5.5mm	
Needle	DP×17 23#	DP×17 25#
Presser foot lifting height	By hand	8mm
	By knee	16mm
Hook	Large lubrication hook	
Lubrication	Automatic lubrication	
Motor output	750W	

3. Installing the oil pan and safety switch magnet (Fig.1)

1. Insert the two head cushion ② into the front corners of the oil pan ①;
2. Insert the two head cushion ③ into the back corners of the oil pan ①;
3. Place the oil pan ④ into the cutouts of table;
4. Insert the two rubber cushion ⑤ into the notches of table.
5. Insert the safety switch magnet ⑥ into the hole of the table near oil pan cutout.

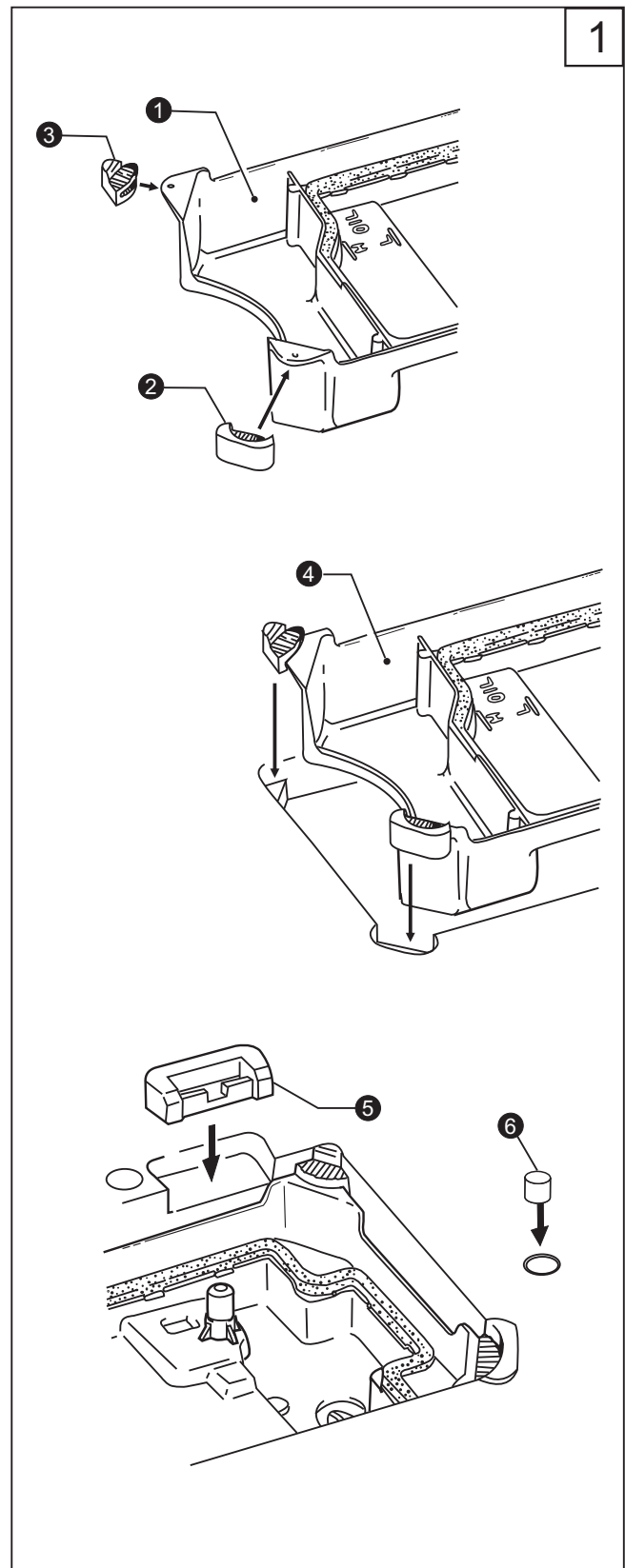

2

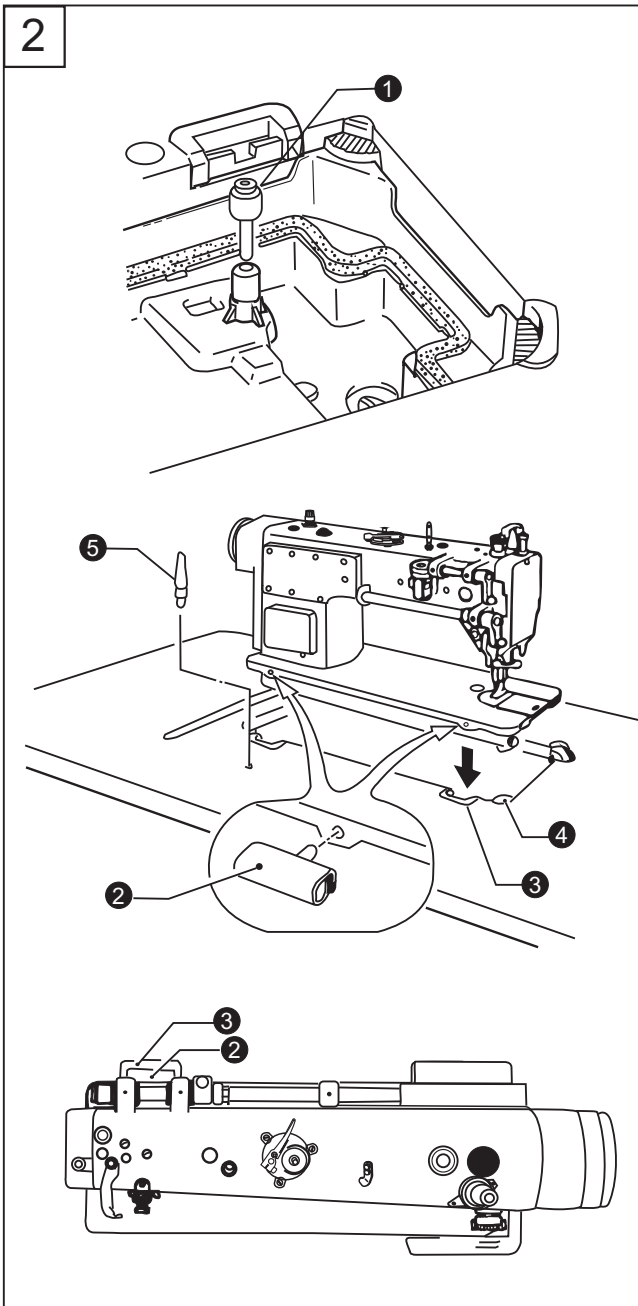

4. Installing the machine head (Fig.2)

1.Insert the knee lifter lifting bar ①.

2.Insert the two hinges ② into the holes in the machine bed.

3.Clamp the two hinges onto the rubber cushions ③ in the work table, and then place the machine head onto the head cushions ④ which are on the top of the oil pan corners.

4.Tap the rest bar ⑤ into the table hole.

NOTE: Tap the rest bar securely into the table hole, if not, the machine head will not be safe when it is tilted back.

3

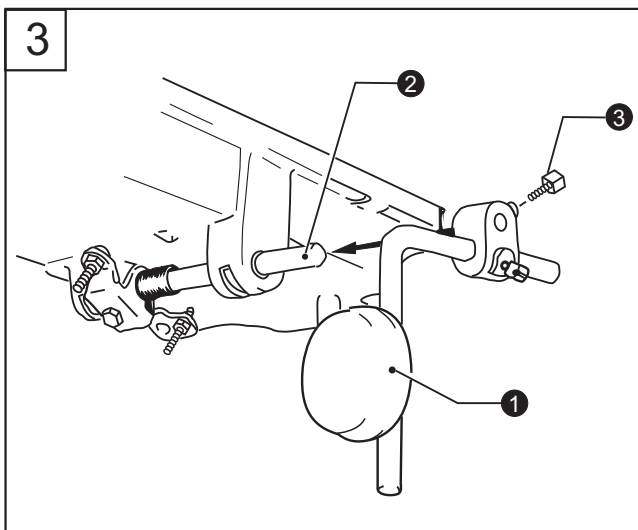

5. Installing the knee lifter assy. (Fig.3)

Insert the knee lifter assy. ① into the shaft ② under the oil pan, and slightly tight the screw ③.

6. Adjusting knee lifter(Fig.4)

- 1.Lower the presser foot ② by turning the presser foot bar lifter ①.
- 2.Loosen the nut ③.
- 3.Turn the screw ⑥ to adjust the bracket ⑤ to 2mm play.
- 4.Securely tighten the nut ③.
- 5.Loosen the nut ⑦.
- 6.Turn the screw ⑧ until the distance between the end of the screw and bracket is approximately 8mm.
- 7.Turn the adjusting screw ③ to adjust, so that the presser foot is at the desired position within a distance of 16mm above the needle plate when the knee lifter plate ④ is fully pressed.
- 8.After adjustment, tighten the nut ⑦.

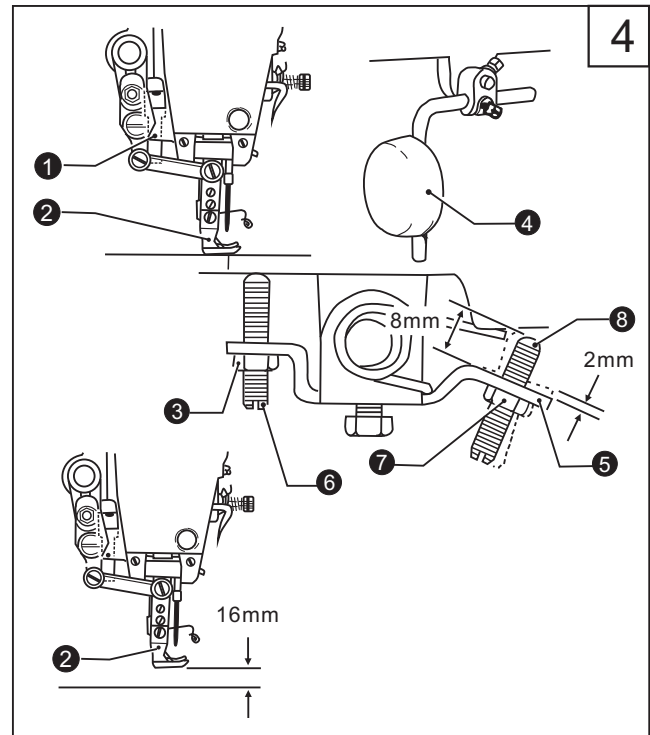

7. Lubrication(Fig.5)

- 1.Oil amount
Please fill the oil according to the mark indicated on the oil pan. Mark (A) means the highest position. Mark (B) means the lowest position. If the oil amount is lower than the Mark (B), oil will not be pumped and machine will be jammed.
- 2.Fill the oil
Please fill the 18# sewing oil into the oil pan until to the Mark (A)
- 3.Change the oil
 - ①Uninstall the screw (C), and drain out the used oil
 - ②Clean the oil pan, and tighten the screw (C), fill the fresh oil again according the requirement.

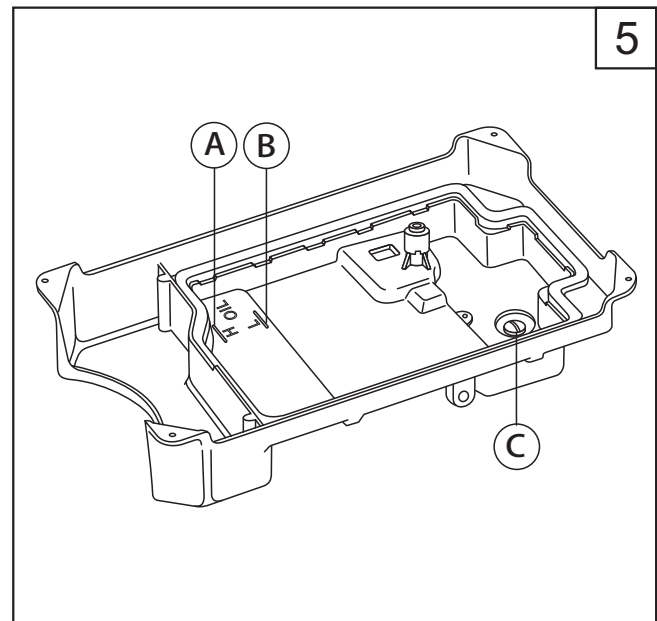

6

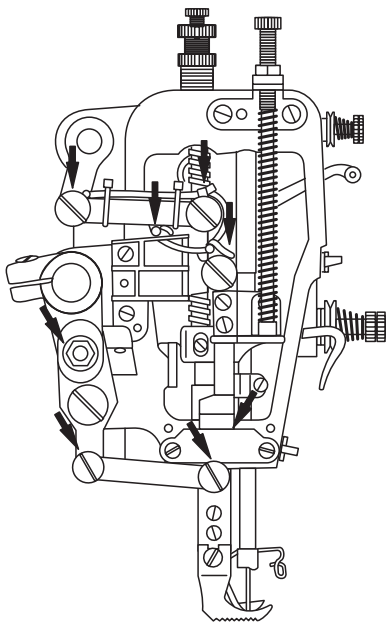
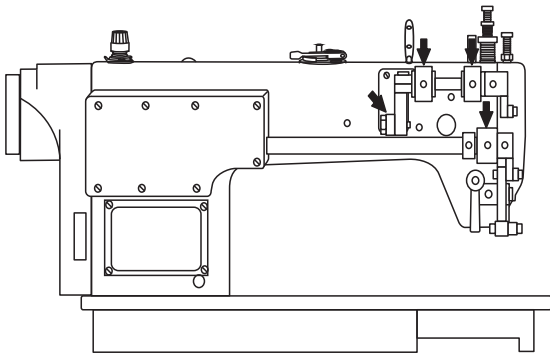
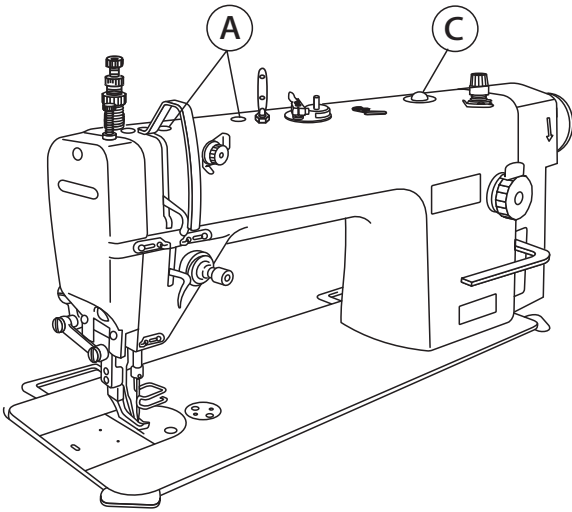

8. Test operation(Fig.6)

Carry out the test operation when start up a new sewing machine for the first time, or restart after a long period of non-use.

Remove the rubber cap (A) on the top of the arm and face plate, fully lubricate the parts showed by the arrows.

Install the face plate again, lift the presser foot and operate the machine at a lower speed of 1000-1500spm, and observe the oil running through the oil gauge window.

After one month, then the speed can be increased according to the different sewing operation.

9. Installing the needle (Fig.7)

1. Turn the machine pulley to move the needle bar ① to its highest position;
2. Loosen the screw ②
3. Insert the needle ③ in a straight line as far as it will go, making sure that the long groove on the needle is at the left, and then securely tighten the screw ②

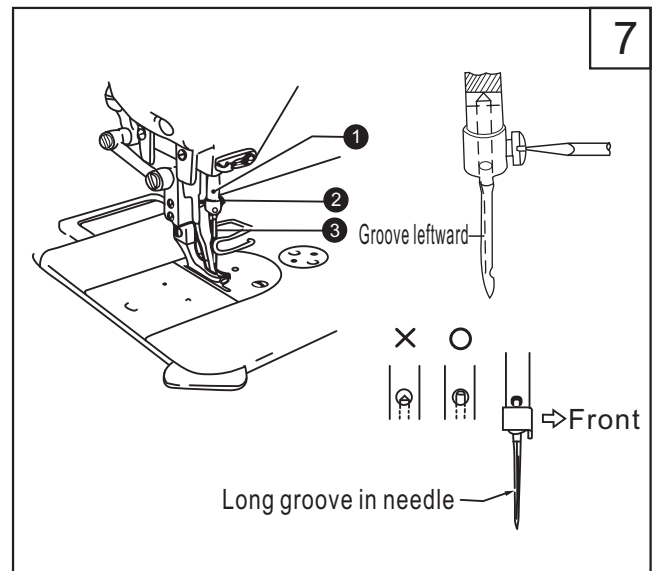

10. Removing the bobbin case (Fig.8)

1. Turn the machine pulley to lift the needle bar to its highest position. Pull the latch ① of the bobbin case upward and then put the bobbin into the bobbin case, finally insert the complete bobbin case with bobbin into the hook shaft.
2. To remove the bobbin case, pull the latch and draw the bobbin case out of the hook.

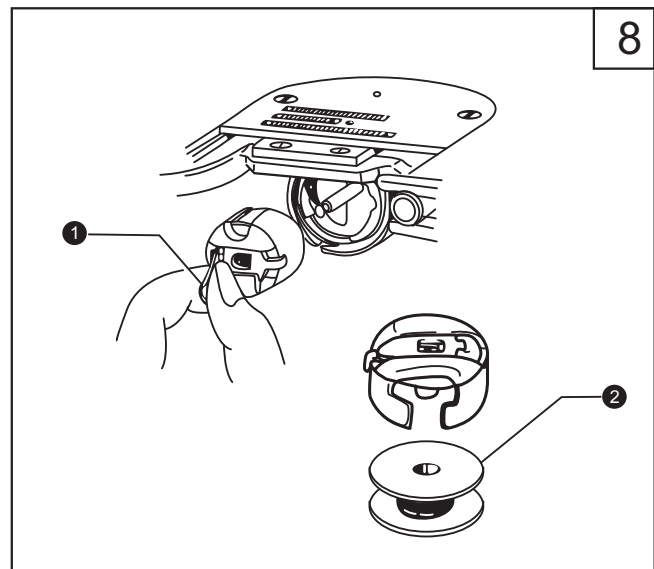

11. Winding the bobbin thread (Fig.9)

1. Turn the power on;
2. Place the bobbin ① onto the bobbin winder shaft ②;
3. Wind the thread several circles around the bobbin in the direction indicated by arrow;
4. Push down the bobbin presser arm ③;
5. Lift the presser foot;
6. Depress the treadle, the winding operation will start;
7. Once finished, the bobbin presser arm ③ will recover automatically.

* If the thread winding is not neat and even, loosen the screw ④ to adjust the position of bobbin winder base.

* Turn the screw ⑥ to adjust the bobbin winding amount

- Tighten the screw to increase the winding amount;
- Loosen the screw to decrease the winding amount.

Note:

The proper winding amount should be around 80% of the bobbin capacity.

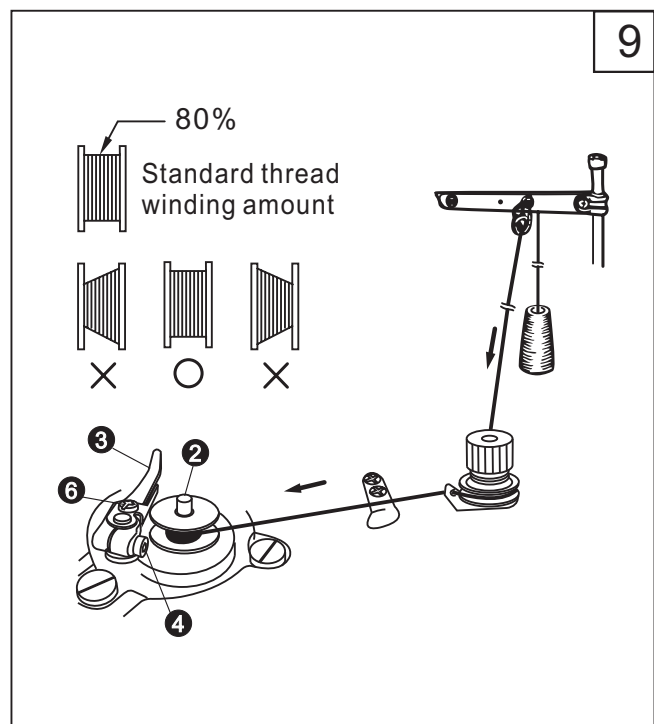

10

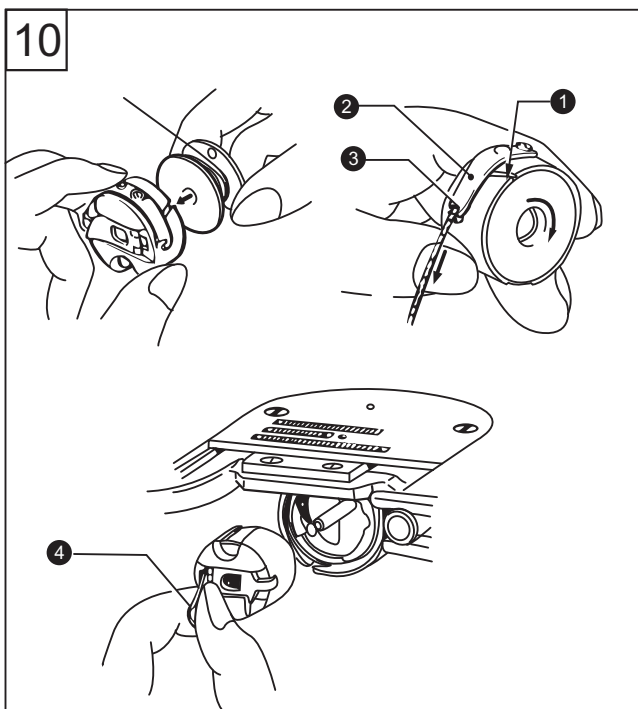

12. Threading the bobbin thread (Fig.10)

1. Turn the machine pulley to lift the needle to its highest position;
2. The bobbin thread should be right twist, place the bobbin into the bobbin case;
3. Pass the thread through the slot ① and spring plate ②, and finally pull it out of the notch ③;
4. Check that the bobbin should turn clockwise if the thread is pulled;
5. Hold the latch ④, and place the bobbin case in the hook.

13. Threading the needle thread (Fig.11)

Raise the thread take-up lever to its highest position. This will make threading easier and will prevent the thread from coming out at the sewing start.

11

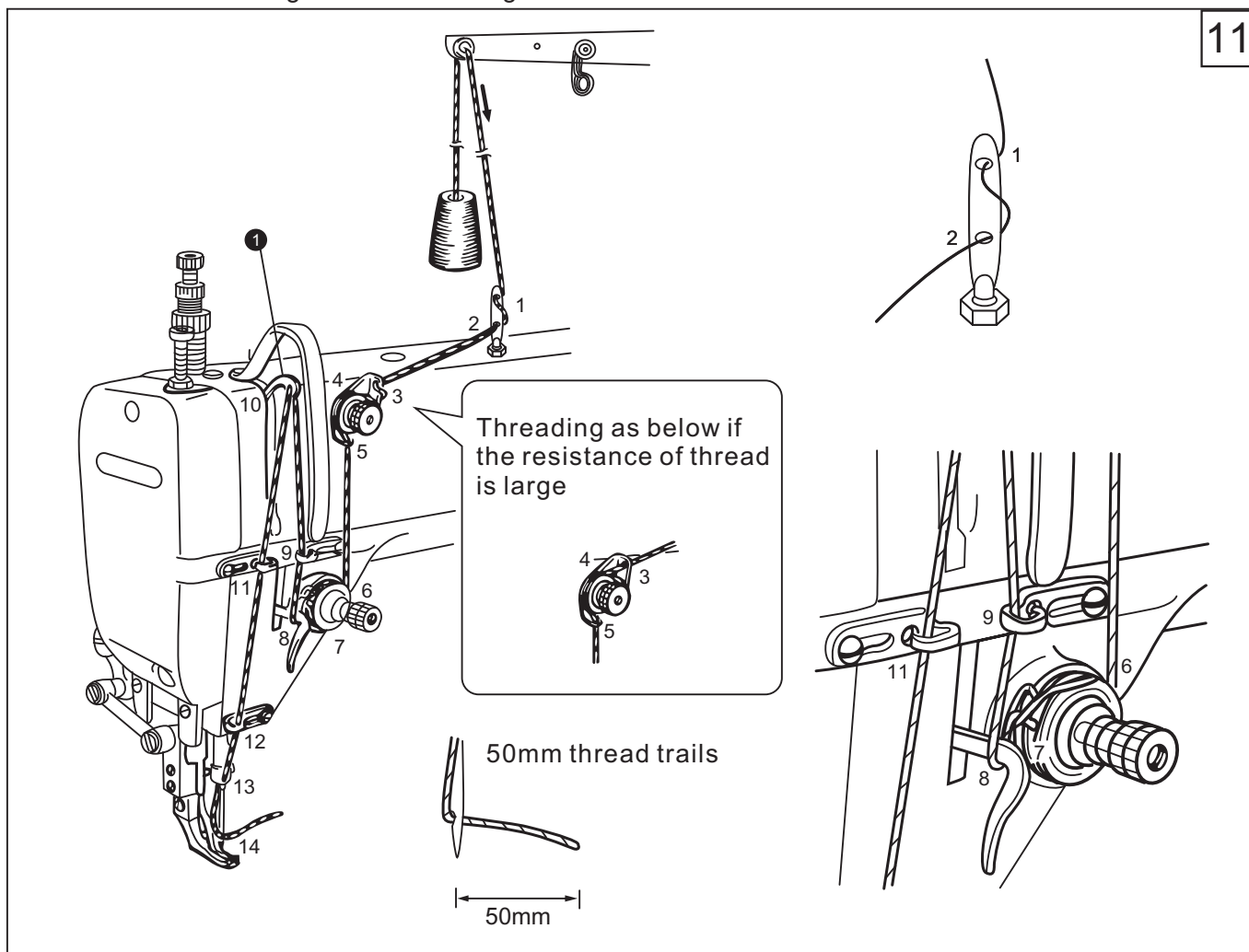

14. Adjusting the stitch length (Fig.12)

While press the stopper ②, turn the stitch length dial ① to make the number on the dial align with the mark on the stopper ②. The number is the stitch length in mm.

* The larger the number, the longer the stitch length will be.

* When turn the dial from a larger setting to a smaller setting, it will be easy to turn if the reverse lever ③ is pressed down.

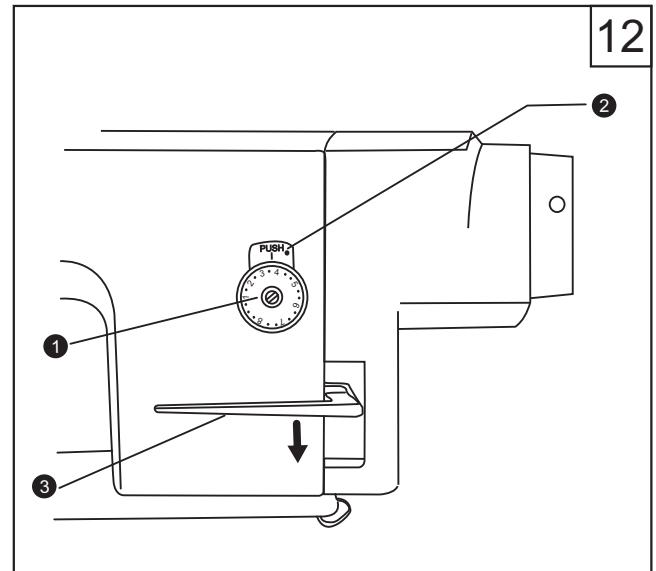

15. Sewing and backtacking (Fig.13)

1. Turn the power on;
2. Depress the treadle to start sewing.

When the reverse lever ① is pressed or the backtacking button is on during sewing, the feed will be reversed. After release, the feed will recover to normal.

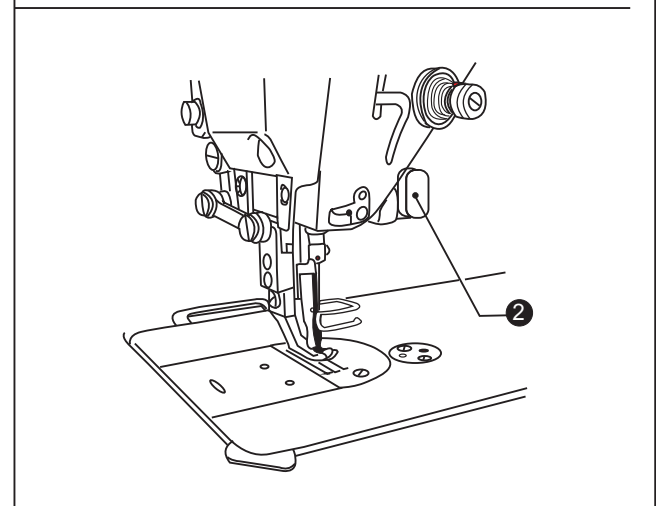
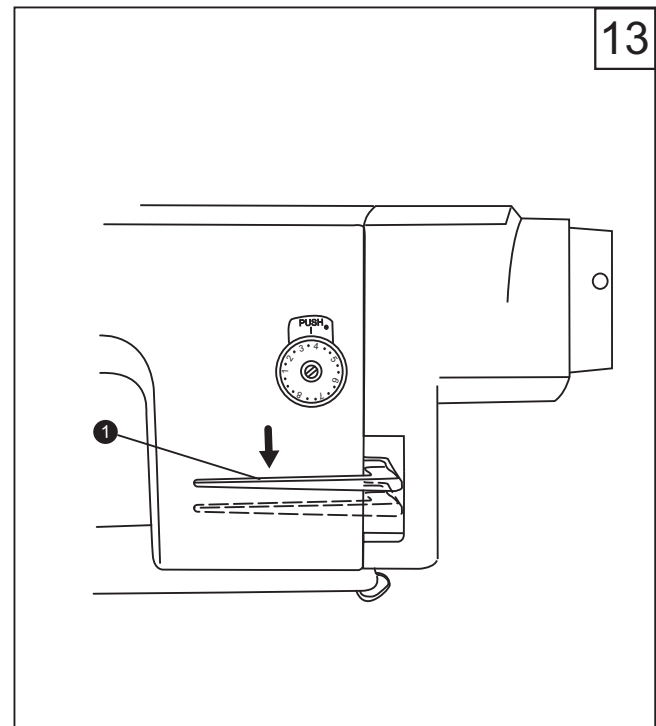

16. Adjusting the thread tension (Fig. 14)

14

Normal stitch



- increase the needle thread tension
- decrease the bobbin thread tension



- decrease the needle thread tension
- increase the bobbin thread tension

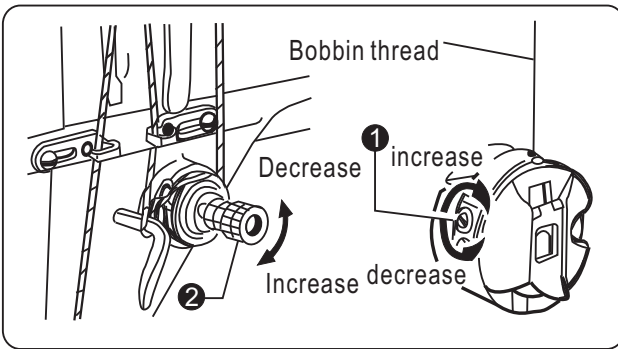

<Bobbin thread tension>

Adjust by turning the screw ① until the bobbin case drops gently by its own weight while the thread end coming out of the bobbin case is held.

<Needle thread tension>

After adjust the bobbin thread tension, adjust the needle thread tension so that a good, even stitch seam is obtained.

1. Lower the presser foot;
2. Adjust by turning the thread tension nut ②.

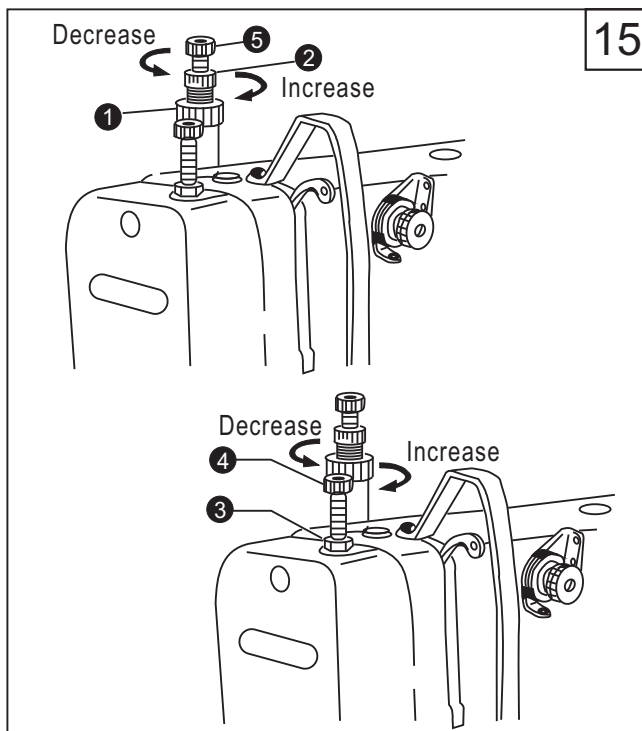

15

17. Adjusting the presser foot pressure (Fig. 15)

<Adjusting the presser foot pressure>

1. Loosen the lock nut ①;
2. Turn the adjusting screw ② to adjust the pressure of presser foot, if it's not enough, please turn the screw ⑤ to increase the pressure.

* The pressure should be as weak as possible, but strong enough so that the material doesn't slip.

3. Tighten the nut ①.

<Adjusting the walking foot presser>

4. Loosen the nut ③;
5. Turn the screw ④ clockwise to increase the pressure, on the contrary, turn the screw ④ counterclockwise to decrease the pressure;
6. Tighten the nut ③.

18. Adjusting the thread tension spring (Fig. 16)

★The standard position of the thread tension spring ① is 5-8mm above the upper surface of the thread guide ③ when the presser foot ② is lowered.

1. Lower the presser foot ②;
2. Loosen the screw ④;
3. Turn the thread tension bracket ⑤ to adjust the spring position;
4. Tighten the screw ④.

★The standard tension of the spring is 0.3-0.6N.

5. Push the needle thread with your finger until it is slightly higher than the thread tension bracket ⑤ and so that the upper thread is not pulled out;

6. Pull the needle thread down until the spring ① is at the same height with the upper surface of thread guide ③, and then measure the tension of the spring.

7. Insert a screwdriver into the slot of the thread tension stud ⑥, and turn the stud to adjust the tension of the spring ①.

Note:

If using a tension gauge ⑦ to measure the tension, take the reading from the scale on the side of the red line.

16

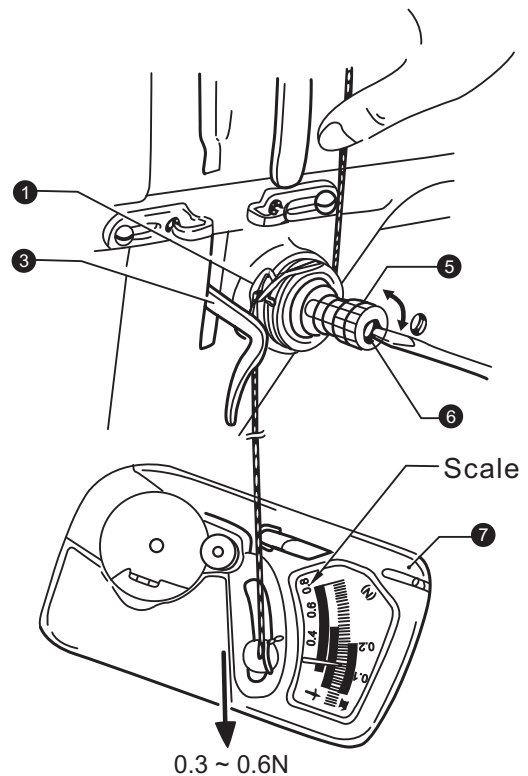
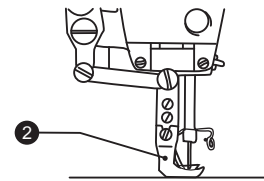
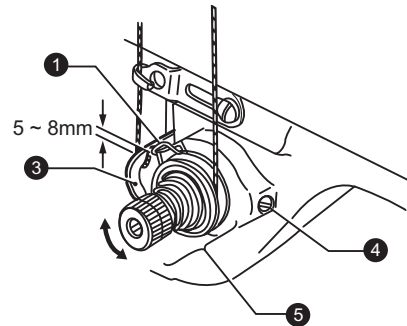

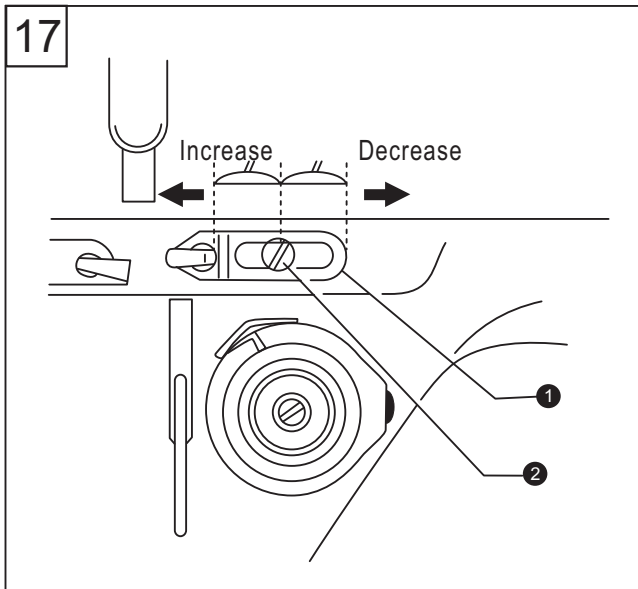

19. Adjusting the upper thread guide (Fig. 17)

The standard position of upper thread guide ① is where the screw ② is in the center of the adjustable range of upper thread guide.
 To adjust the position, loosen the screw ② and move the thread guide.
 If stitch the heavy materials, move the thread guide leftward. (To increase the thread take-up tension)
 If stitch the light materials, move the thread guide rightward. (To decrease the thread take-up tension)

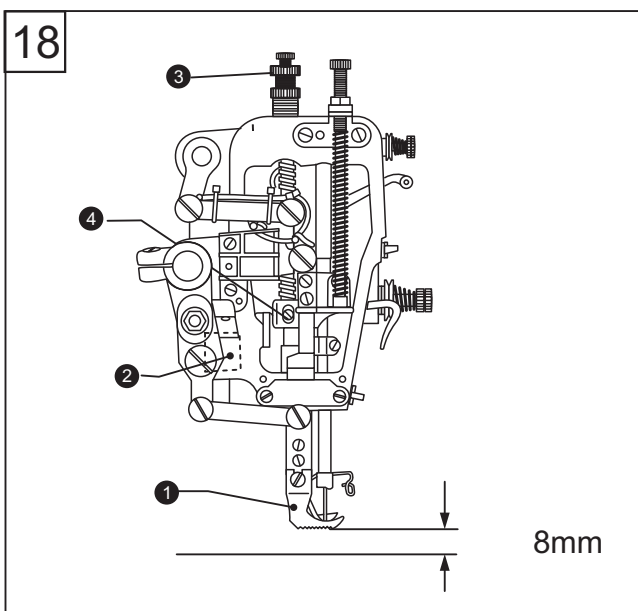

20. Adjusting the presser foot height (Fig. 18)

The standard height of presser foot ① is 8mm when it is lifted by hand.

1. Loosen the screw ③ to lift the presser bar
2. Put a measurement gauge with 8mm height under the presser foot;
3. Loosen the screw ④ and adjust the height of presser foot;
4. Tighten the screw ④.

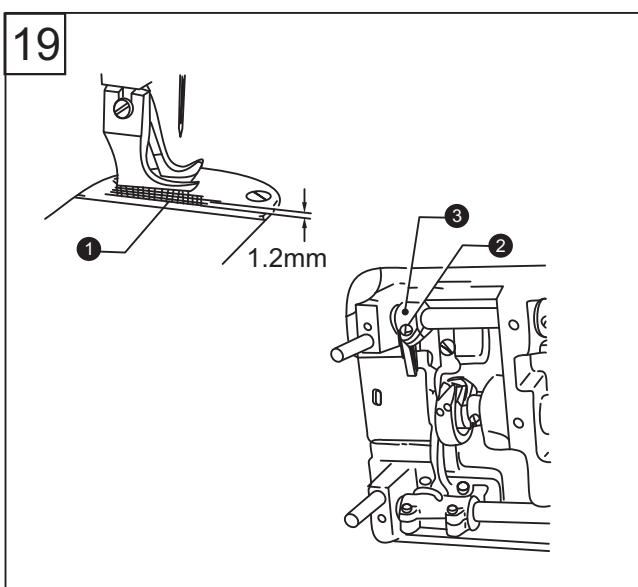

21. Adjusting the feed dog height (Fig. 19)

1. Set the stitch length maximum, when the feed dog ① is at its highest position above the needle plate, the standard height is 1.2mm
2. Loosen the screw ② and turn the feed lifting arm ③ to adjust the height of feed dog.

22. Adjusting the feed dog angle (Fig. 20)

The standard angle of the feed dog is: when the feed dog is at its highest position above the needle plate, the Mark on the feed bracket shaft is on the horizontal position.

1. Turn the machine pulley to lift the feed dog to its highest position;
2. Loosen the screw ⑦;
3. Turn the feed bracket shaft in the direction of the arrow within a range of 90° with respect to the standard angle position.

* In order to prevent puckering, lower the front of the feed dog (Fig. A)

* In order to keep the materials straight, raise the front of the feed dog (Fig. B)

4. Securely tighten the set screw ⑦.

It's necessary to adjust the feed dog height again after this adjustment.

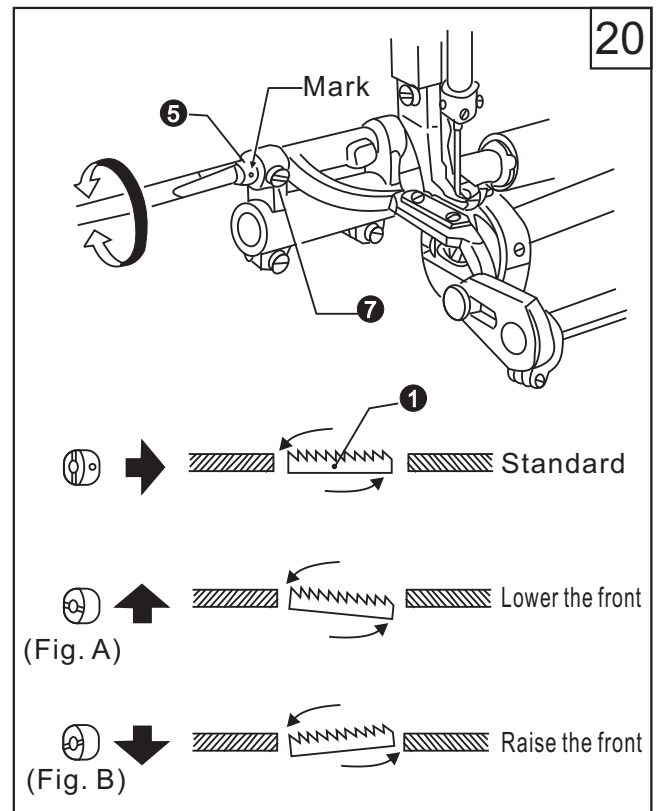

23. Adjusting the difference of stitch length between the forward and backtacking (Fig. 21)

1. Remove the back cover;
2. Loosen the screw ① and turn the connecting stud ②

* Turn the stud ② clockwise, the forward stitch length will be longer and the backtacking stitch length will be shorter;

* Turn the stud ② counterclockwise, the forward stitch length will be shorter and the backtacking stitch length will be longer;

3. Tighten the screw ①.

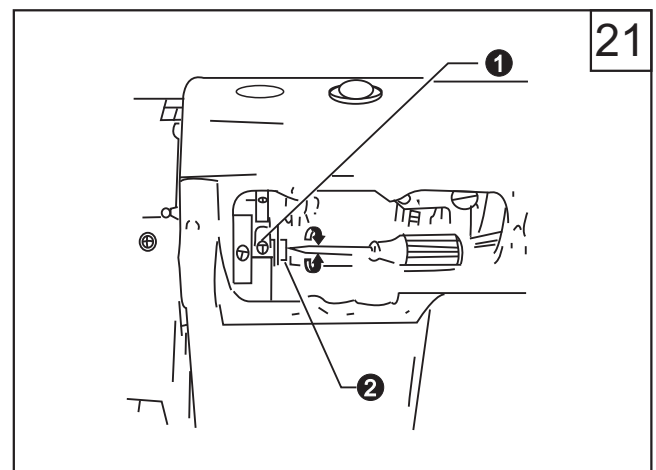

24. Adjusting the tension release (Fig. 22)

The opening time of the thread tension discs can be adjusted.

Remove the rubber cap on the rear of arm, and turn the screw ①, then the thread release cam ② can be moved left or right.

Move the cam rightward, the release time will be slow

Move the cam leftward, the release time will be quick.

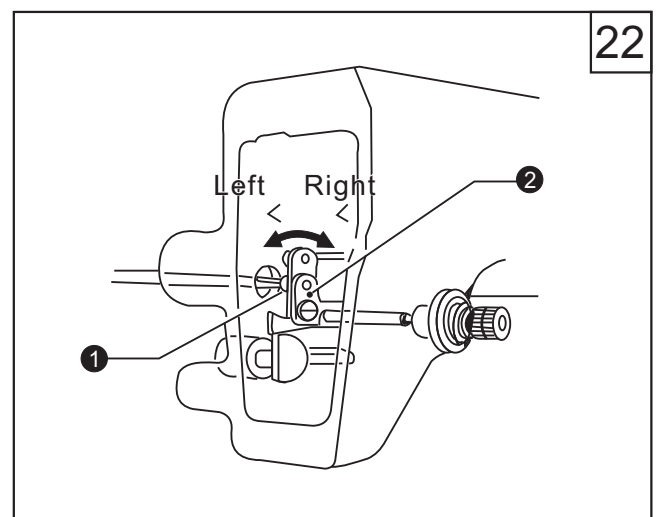

23

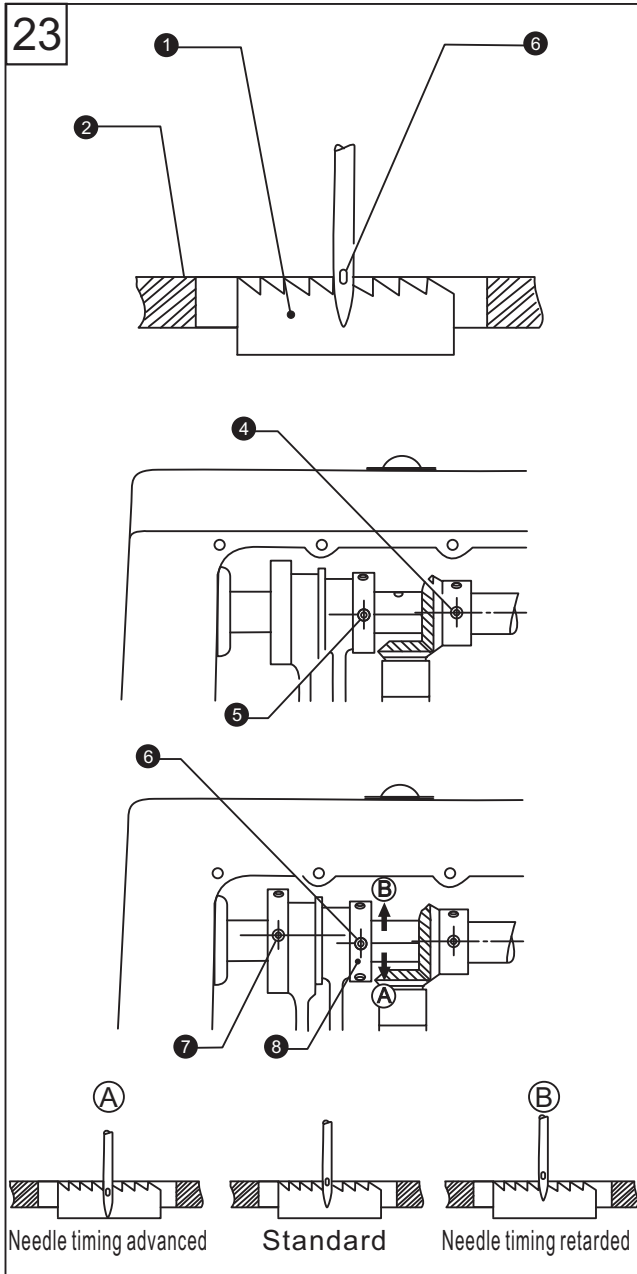

25. Adjusting the timing of needle and feed mechanism (Fig. 23)

The standard timing is when the feed dog is lowered from its highest position until it is flush with the top of the needle plate ②, and the needle eye ③ is also aligned horizontally with the surface.

Adjust by changing the phases of feed cam and eccentric wheel UD

1. Remove the rear cover
2. Turn the machine pulley in reverse direction, set the second screw ④ on the gear of upper shaft as reference mark, make the third screw ⑤ of eccentric wheel UD slightly lower than the reference mark screw ④;
3. Continue to turn the machine pulley, set the second screw ⑥ of eccentric wheel UD as reference mark, make the third screw ⑦ of feed cam slightly higher than the reference mark screw ⑥.
4. If need a non-timing position, loosen the three screws of eccentric wheel UD, adjust the eccentric cam ⑧ in the direction of arrow (A) or (B)
To increase the tension of thread, turn the eccentric cam ⑧ to direction (A)
To avoid the needle bent, turn the eccentric cam ⑧ to direction (B)
5. After adjustment, tighten all of the screws.

24

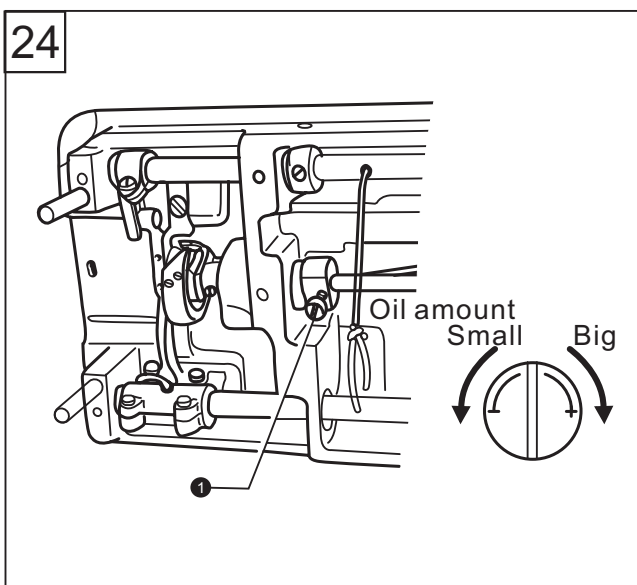

26. Adjusting the rotary hook lubrication amount (Fig. 24)

Tilt back the machine head, and turn the oil adjustment screw ① to adjust the hook oiling amount.

27. Adjusting the height of needle bar and the timing with hook (Fig. 25)

When the needle bar ① is at its lowest position, the top reference line (A) on the needle bar should be aligned with the bottom edge of the needle bar bush ②.

1. Turn the machine pulley to lower the needle bar to its lowest position;
2. Take out the rubber cap ③;
3. Loosen the screw ④, and move the needle bar ① to proper position;
4. Tighten the screw ④;
5. Close the rubber cap ③.

Lift the needle bar ① from the lowest position, when the second reference line (B) on the needle bar is aligned with the bottom edge of the needle bar bush ②, the tip ⑤ of the hook should be aimed at the center of needle ⑥.

1. Turn the machine pulley to raise the needle bar ① from its lowest position until the reference line (B) is aligned with the bottom edge of the needle bar bush ②

* When the needle bar moves up 2mm, the clearance between the upper of needle hole and the hook tip should be 1.3-1.8mm

2. Loosen the screw ⑦, and make the hook tip aimed at the center of needle ⑥, the clearance between the hook tip and needle should be 0.05mm
3. Tighten the screw ⑦.

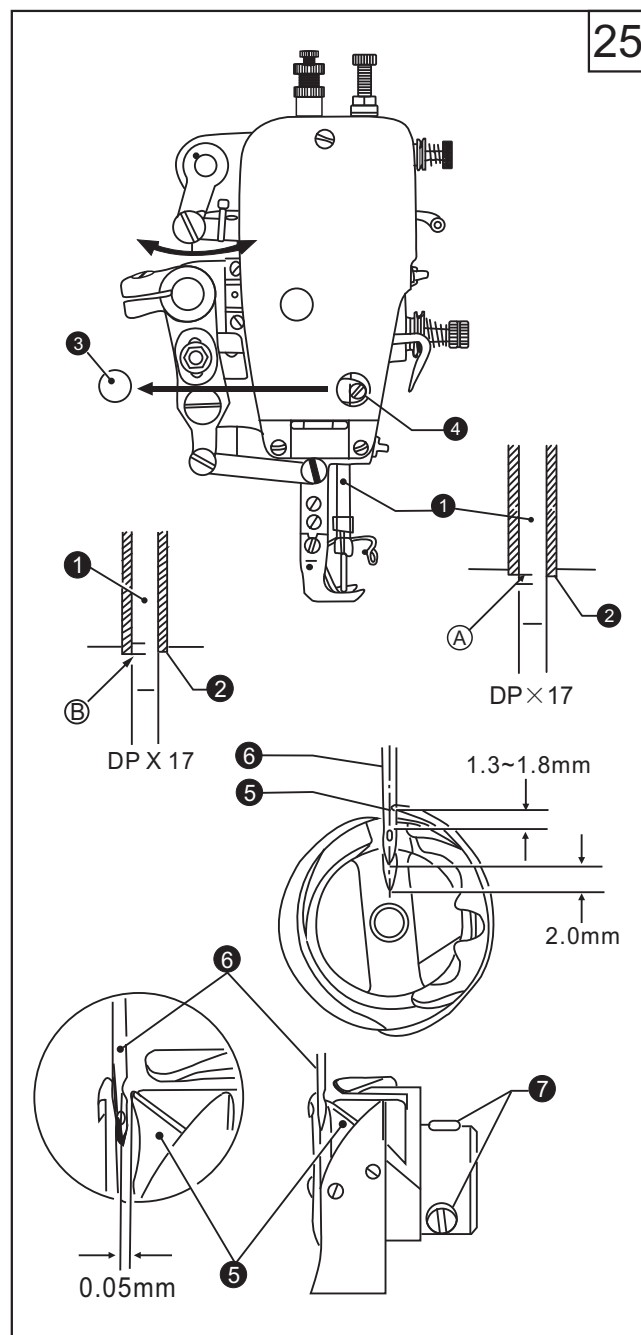

28. Adjusting the oil pump (Fig. 26)

If the oil is not circled observed from the oil gauge window at a lower sewing speed, turn the oil adjustment plate ① to cover the oil hole.

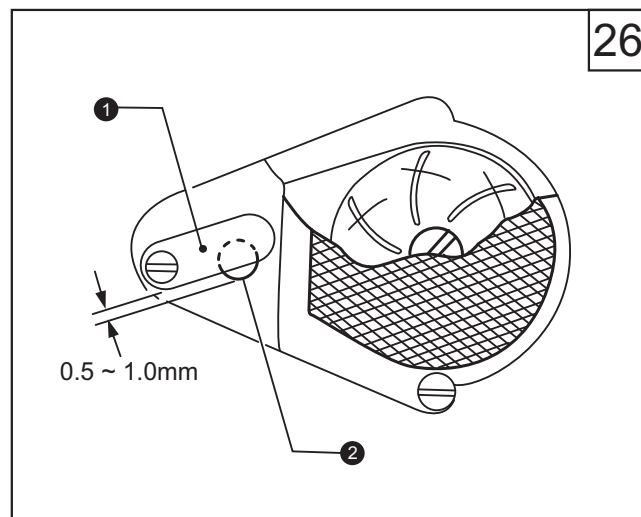

27

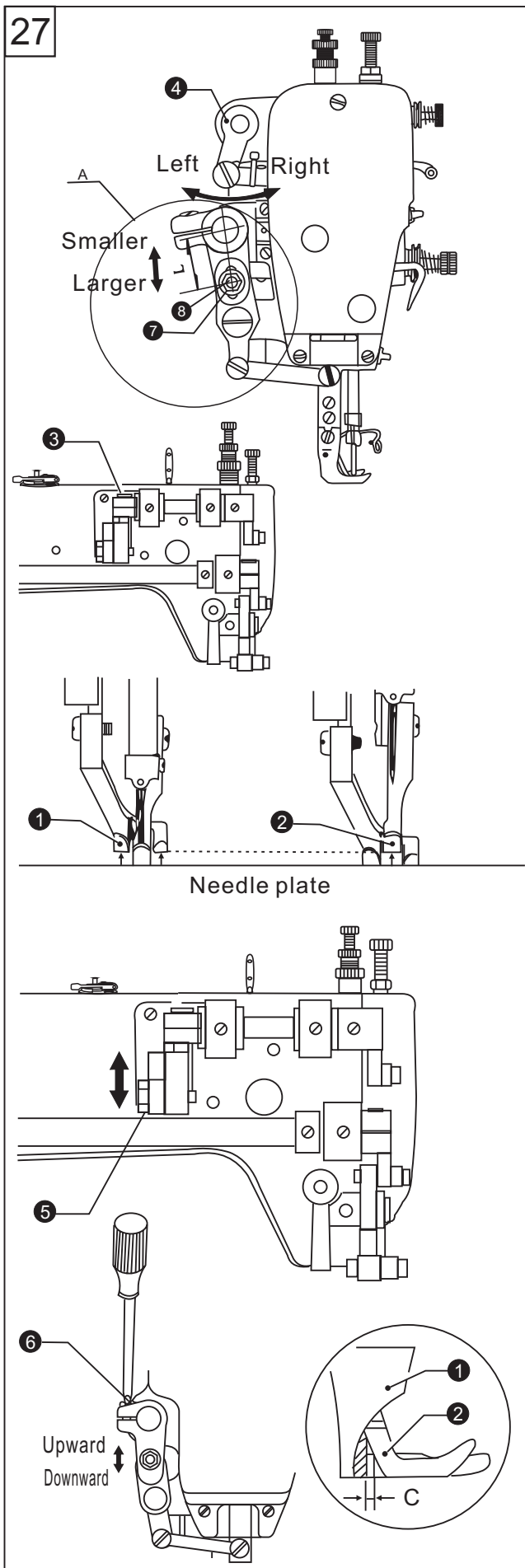

29. Adjusting the lifting amount of presser feet (Fig. 27)

1. Vertical movement of presser foot and walking foot

★The presser foot ① and walking foot ② move vertically one after another

★Usually the stroke of walking foot and presser foot is same or the stroke of walking foot is slightly lower.

Place the thread take-up lever at the lowest position, and lower the presser bar lifter, loosen the screw ③ and move the upper feed lifting cam ④.

Move it rightward to make the stroke of two feet be equal

Move it leftward to make the stroke of presser foot be smaller.

2. Adjusting the lifting amount of presser feet
Adjust the lifting amount of two feet to match the materials to be sewn.

Loosen the screw ⑤, and move the screw upward to increase the lifting amount or move the screw downward to decrease the lifting amount.

3. Adjusting the forward/backward clearance of the two feet

To keep the front groove of presser foot not strike the rear of the walking foot, the clearance of C must be kept about 3mm.

Loosen the screw of feed arm R, and then turn the feed rock shaft ⑥ to adjust.

4. Adjusting the feed amount of walking foot (Fig. A)

★The standard ration of feed amount between feed dog and walking foot is 1:1

The feed amount of walking foot can be adjusted to suit for the materials to be sewn.

Loosen the nut ⑦, and move the slide block ⑧
Upward: decrease the distance L to make the feed amount be smaller

Downward: increase the distance L to make the feed amount be larger

30. Clean (Fig. 28)

28

1. Raise the presser foot;
2. Remove the two screws ① and needle plate ②;
3. Clean the feed dog with a soft brush;
4. Install the needle plate ② by two screws ①.

5. Turn the machine pulley slowly and check if the needle drops into the hole center of needle plate

★If not

- Check if the needle is bent
- Loosen the screw ①, and reinstall the needle plate ②

6. Turn the machine pulley and lift the needle above the needle plate, check if the needle tip is blunt, if yes, change a new one.

7. Tilt back the machine head

8. Remove the bobbin case ④

9. Clean the hook with a soft cloth and check if the hook is worn out

10. Take out the bobbin from the bobbin case, and clean the bobbin case with a soft cloth

11. Insert the bobbin into the bobbin case and place the bobbin case back into the machine

12. Clean the dust on the filter (A) of oil pump.

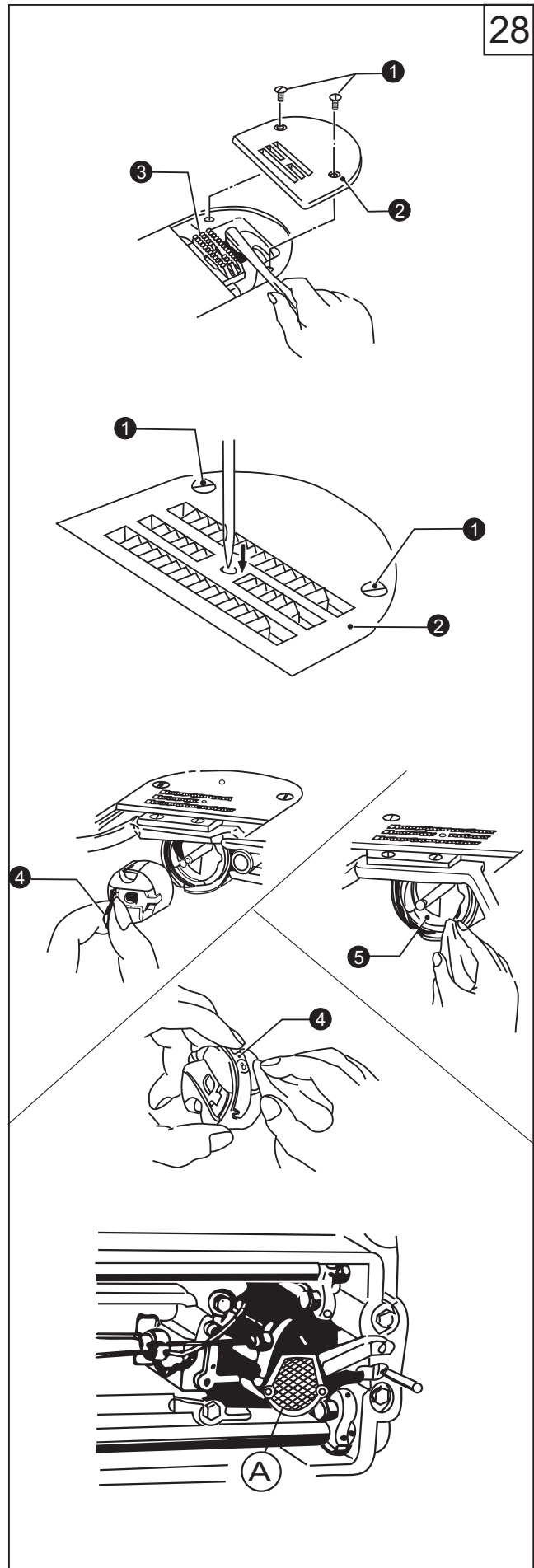

Parts Manual

1. Casting mechanism

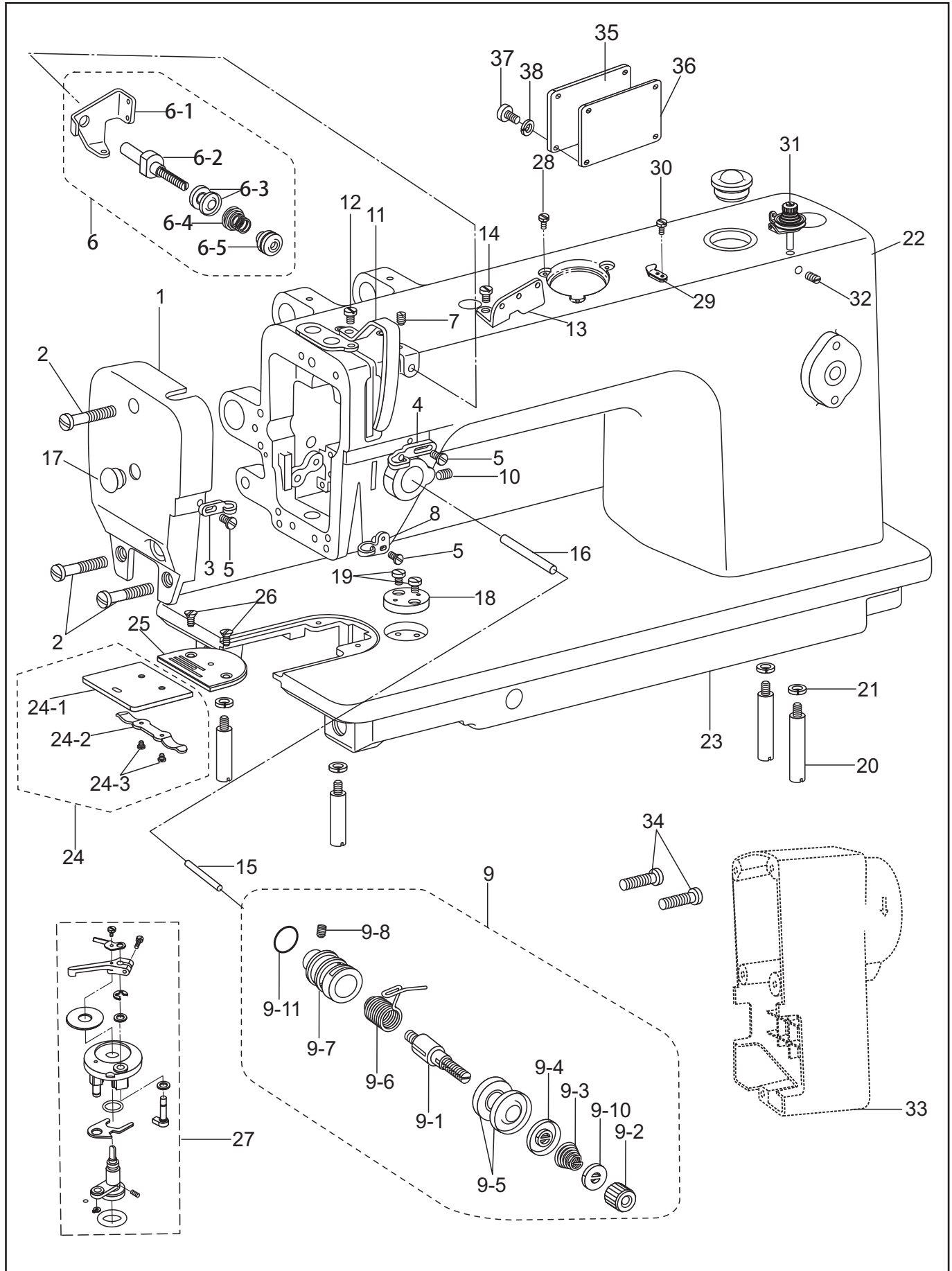

1. Casting mechanism

No.	Part number	Name	Qt.		Remark
			0303D	0303DCX	
1	1KT1-002	Face plate	1	1	
2	7WF4-004	Screw	3	3	
3	22T1-003C5	Thread guide	1	1	
4	22T1-014	Thread guide	1	1	
5	22T1-003C6	Screw	3	3	
6	36T2-006D	Thread guide assy.	1	1	
6-1	36T2-006D1	Thread guide	1	1	
6-2	36T2-006D2	Pre-tension stud	1	1	
6-3	22T2-009E3	Tension disc	2	2	
6-4	2KT2-011	Tension spring	1	1	
6-5	36T2-006D4	Adjusting screw	1	1	
7	20T1-004	Set screw	1	1	
8	7WF4-015	Thread guide	1	1	
9	33T4-008C	Thread tension bracket assy.	1	/	
	11WF4-006	Thread tension bracket assy.	/	1	
9-1	22T1-012F1	Tension stud	1	1	
9-2	22T1-012F2	Tension nut	1	1	
9-3	33T4-008C1	Tension spring	1	/	
	11WF4-006A	Tension spring	/	1	
9-4	22T1-012F4	Disc presser	1	1	
9-5	22T1-012F5	Disc, tension	2	2	
9-6	22T1-012F6	Thread take-up spring	1	1	
9-7	22T1-012F7	Thread tension bracket	1	1	
9-8	22T1-012F8	Set screw	1	1	
9-10	22T1-012F10	Stopper	1	1	
9-11	22T1-012F11	O ring	1	1	
10	22T1-013	Set screw	1	1	
11	1KT1-003	Cover	1	1	
12	22T2-004	Screw	1	1	
13	36T2-004	Thread retainer	1	1	
14	36T2-005	Screw	1	1	
15	2KT4-002	Tension release pin	1	1	GB93 6
16	2KT4-003	Tension release stud	1	1	
17	7WF4-030	Rubber plug	1	1	
18	7WF4-005	Ruler plate	1	1	
19	1WF3-025	Screw	2	2	
20	7WF4-013	Bed leg	4	4	
21		Washer, spring	4	4	
22	283WF1-001	Arm	1	/	
		Arm	/	1	
23	7WF4-001	Bed	1	1	
24		Slide plate assy.	1	1	
24-1	7WF4-006	Slide plate	1	1	
24-2	20T1-013F2	Spring plate	1	1	
24-3	20T1-013F3	Screw	2	2	
25	33T4-012-A	Needle plate	1	/	
	11WF4-004	Needle plate	/	1	GB/818 M5X25
26	22T1-020	Screw	2	2	
27	258WF1-007	Bobbin thread winder assy.	1	1	
28	92WF2-027	Screw	3	3	
29	52WF2-043	Cutter	1	1	
30	36WF2-031	Screw	2	2	
31	258WF1-005	Bobbin thread tension assy.	1	1	
32	1WF5-019	Screw	1	1	
33		Motor cover	1	1	
34		Screw	5	5	
35	273WF1-005	Back cover	1	1	

2. Needle bar and thread take-up mechanism

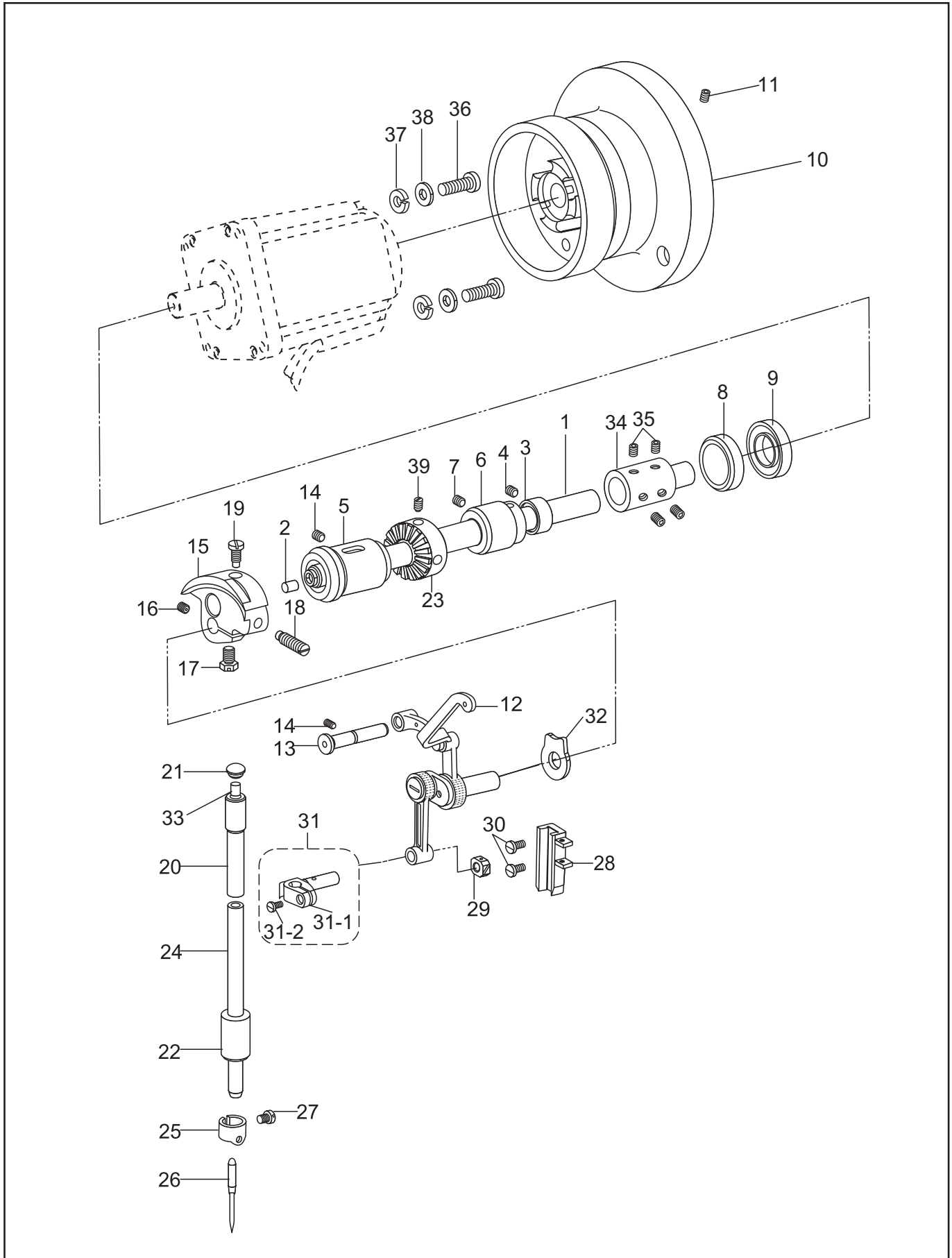

2. Needle bar and thread take-up mechanism

No.	Part number	Name	Qt.		Remark
			0303D	0303DCX	
1	271WF2-001	Upper shaft	1	1	
2	22T3-001A2	Robber cap	1	1	
3	22T3-002B1	Collar	1	1	
4	22T3-002B2	Screw	2	2	
5	4WF1-006A	Bush, L	1	1	
6	4WF1-002	Bush, M	1	1	
7	J0.0.40	Set screw	1	1	φ20xφ42x12
8		Bearing, R	1	1	
9	258WF2-004	Oil seal	1	1	
10	273WF2-001	Hand wheel	1	1	
11	258WF2-007	Screw	2	2	
12	33T1-004B	Thread take-up lever set	1	/	
	11WF1-001B	Thread take-up lever set	/	1	
13	33T1-002	Support shaft	1	1	
14	J0.0.5	Set screw	2	2	
15	4WF1-007A	Thread take-up crank	1	1	
16	33T1-006C3	Screw	1	1	
17	22T2-005B3	Screw	1	1	
18	33T1-006C2	Screw	1	1	
19	20T2-007	Screw	1	1	
20	22T2-008	Bush, needle bar, upper	1	1	
21	22T2-011	Robber cap	1	1	
22	2KT1-002	Bush, needle bar, lower	1	1	DPX17 23#
23	258WF2-002	Friction wheel	1	1	DPX17 25#
24	33T1-017	Needle bar	1	1	
25	22T2-015	Thread guide	1	1	
26		Needle	1	/	
		Needle	/	1	
27	22T2-017	Set screw	1	1	
28	2KT1-003	Guide	1	1	
29	33T1-013	Slide block	1	1	
30	22T2-019	Screw	2	2	
31	33T1-015H	Needle bar clamp assy.	1	1	
31-1	22T8-001A8	Needle bar clamp	1	1	GB/T65 M5X20
31-2	22T8-001A9	Set screw	1	1	GB/T859 5
32	33T1-005	Washer	1	1	GB/T95 5
33	22T1-010	Felt	1	1	
34	258WF2-003	Shaft coupling	1	1	
35	19WF3-005	Screw	4	4	
36		Screw	4	4	
37		Spring washer	4	4	
38		Washer	4	4	
39	6K2-043	Screw	2	2	

3. Presser foot mechanism

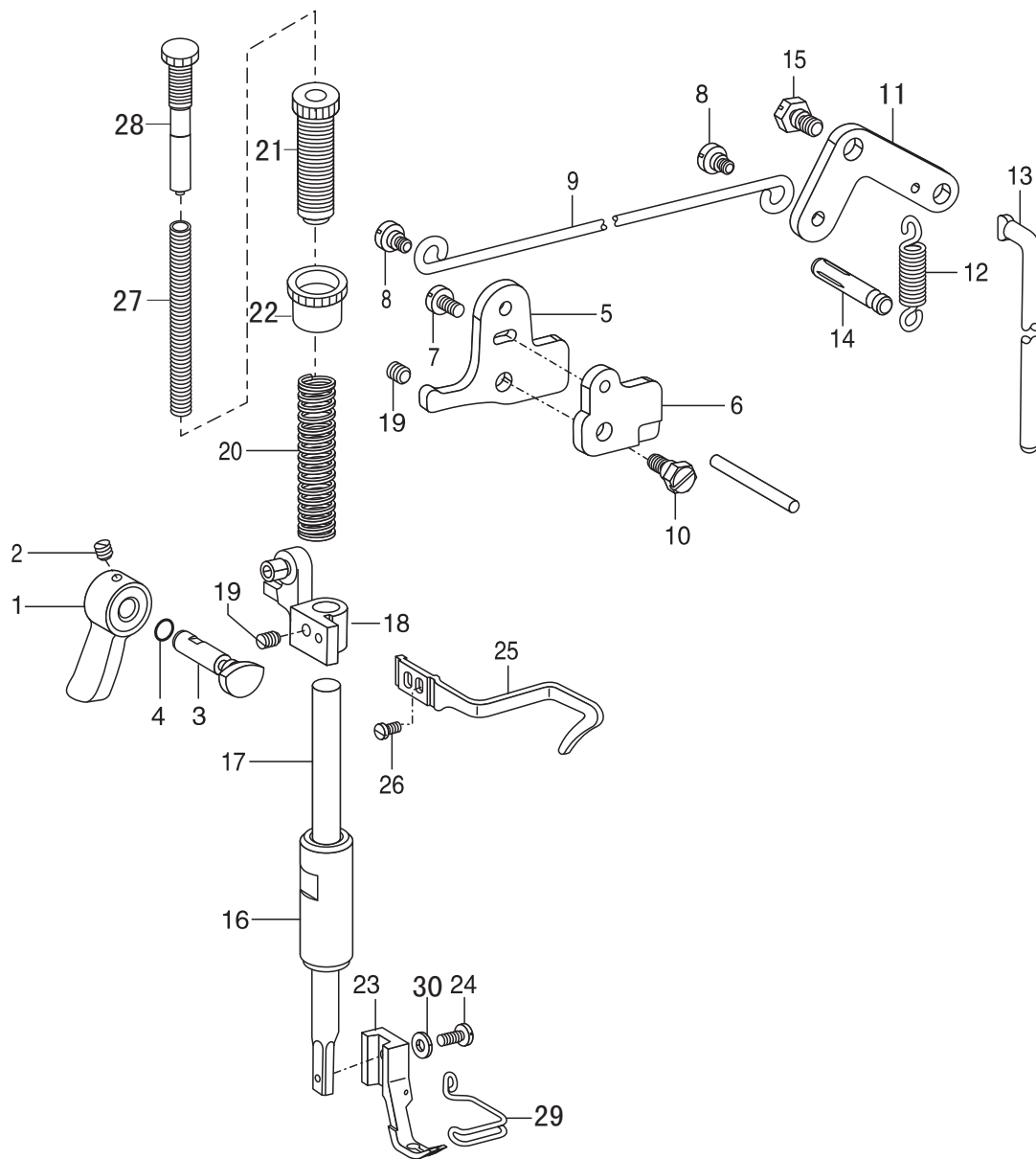

3. Presser foot mechanism

No.	Part number	Name	Qt.		Remark
			0303D	0303DCX	
1	33T3-003	Presser bar lifter	1	1	
2	22T1-011	Screw	1	1	
3	4WF3-002	Lifter crank	1	1	
4		O ring	1	1	GB3452.1 4.5×1.8G
5	22T7-004B _{1a}	Lifter lever	1	1	
6	2KT4-001	Guide plate	1	1	
7	22T7-004B _{1c}	Screw	1	1	
8	22T7-004B ₂	Screw	2	2	
9	1KT4-004	Collecting rod	1	1	
10	22T7-005A	Screw	1	1	
11	22T7-007 _{c1}	Lever	1	1	
12	22T7-007 _{c2}	Spring, extension	1	1	
13	4WF3-001	Knee lifter bar	1	1	
14	22T7-008	Spring hook	1	1	
15	22T7-005 _B	Shoulder screw	1	1	
16	34T3-305	Bush	1	1	
17	241WF5-001	Presser bar	1	1	
18	7WF3-001	Guide bracket	1	1	
19	61-04-01/B308	Screw	1	1	
20	20T4-002	Spring, compression	1	1	
21	233WF6-002	Adjusting screw, presser	1	1	
22	233WF6-003	Adjusting nut, presser	1	1	
23	7WF3-003	Presser foot, inside	1	/	
	11WF3-001	Presser foot, inside	/	1	
24	22T7-015	Screw	1	1	
25	7WF3-002	Thread guide	1	1	
26	33T3-006	Screw	1	1	
27	233WF6-005	Adjusting spring	1	1	
28	233WF6-004	Adjusting screw	1	1	
29	7WF3-004	Finger guard	1	1	
30		Washer	1	1	GB97.1 4

4. Feed mechanism

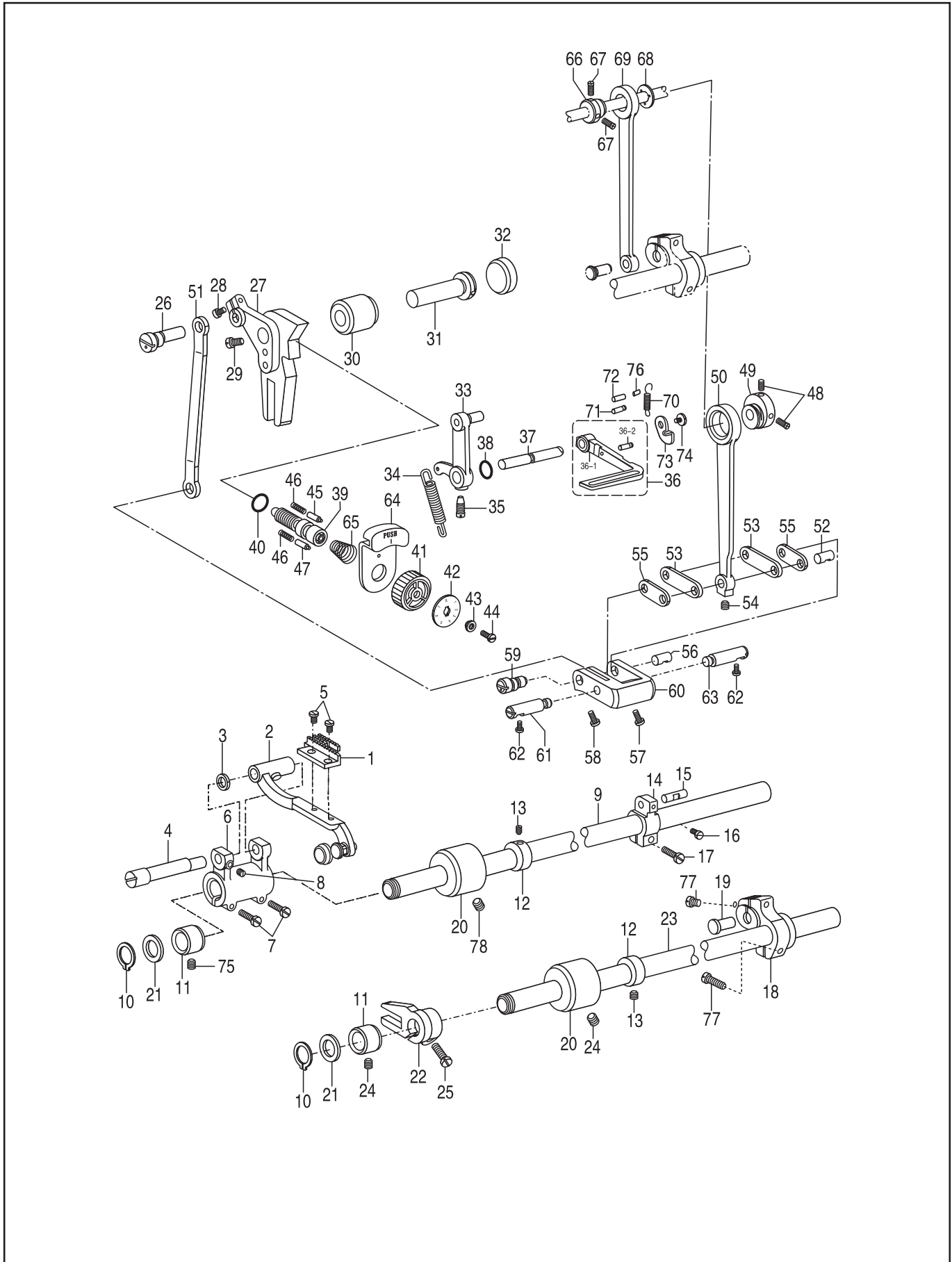

4. Feed mechanism

No.	Part number	Name	Qt.		Remark
			0303D	0303DCX	
1	20T3-008	Feed dog	1	/	
	75WF4-001	Feed dog	/	1	
2	36T4-001A1a1	Feed bar	1	/	
	75WF4-005A	Feed bar	/	1	
3	51T5-001A6	Washer	1	1	
4	36T4-001A2	Shaft	1	1	
5	J0.0.50	Screw	2	2	
6	4WF2-002	Feed rock arm	1	1	
7	61-04-01/B504	Screw	2	2	
8	22T2-019	Screw	1	1	GB894.1 15
9	7WF2-004	Feed shaft	1	1	
10		Retaining ring	2	2	
11	7WF2-002	Bush, L	2	2	
12	22T3-002B1	Collar	2	2	
13	22T3-002B2	Set screw	4	4	
14	4WF2-006	Feed rocker arm	1	1	
15	82T2-003C1a10-2	Stud	1	1	
16	36T5-008E5	Set screw	1	1	
17	22T6-008D3	Screw	1	1	
18	68WF3-011	Feed lifting arm	1	1	
19	22T6-007	Pin	1	1	
20	7WF2-003	Bush, M	2	2	
21	51T5-013	Washer	2	2	
22	36T4-018H1D1	Feed lifting arm	1	/	
	75WF4-003	Feed lifting arm	/	1	
23	7WF2-001	Shaft	1	1	
24	J0.0.5	Screw	2	2	
25	22T6-008D3	Screw	1	1	
26	4WF2-012	Connecting stud	1	1	
27	7WF2-012	Feed regulator	1	/	
	75WF4-003	Feed regulator	/	1	
28	20T2-031	Screw, L	1	1	
29	22T5-010D4	Screw, S	1	1	
30	258WF4-002	Bush	1	1	
31	22T5-004	Shaft	1	1	
32	258WF4-003	Rubber cap	1	1	6.3×1.8G GB3452.1-92
33	7WF2-009	Pin assy. Lever	1	1	
34	1KT3-002	Spring, extension	1	1	14×2.4
35	22T5-013	Screw	1	1	
36	2KT3-003	Reverse stitching lever assy.	1	1	
36-1	2KT3-003a	Reverse stitching lever	1	1	
36-2	2KT3-003b	Spring hook pin	1	1	
37	2KT3-002	Shaft	1	1	
38					
39	36T5-007D1	O ring	1	1	
40	33T2-030-A	Adjusting screw	1	1	
41	36T5-007D2	O ring	1	1	
42	4WF2-004A	Stitch length dial	1	/	
	75WF2-004	Stitch length plate	/	1	

4. Feed mechanism

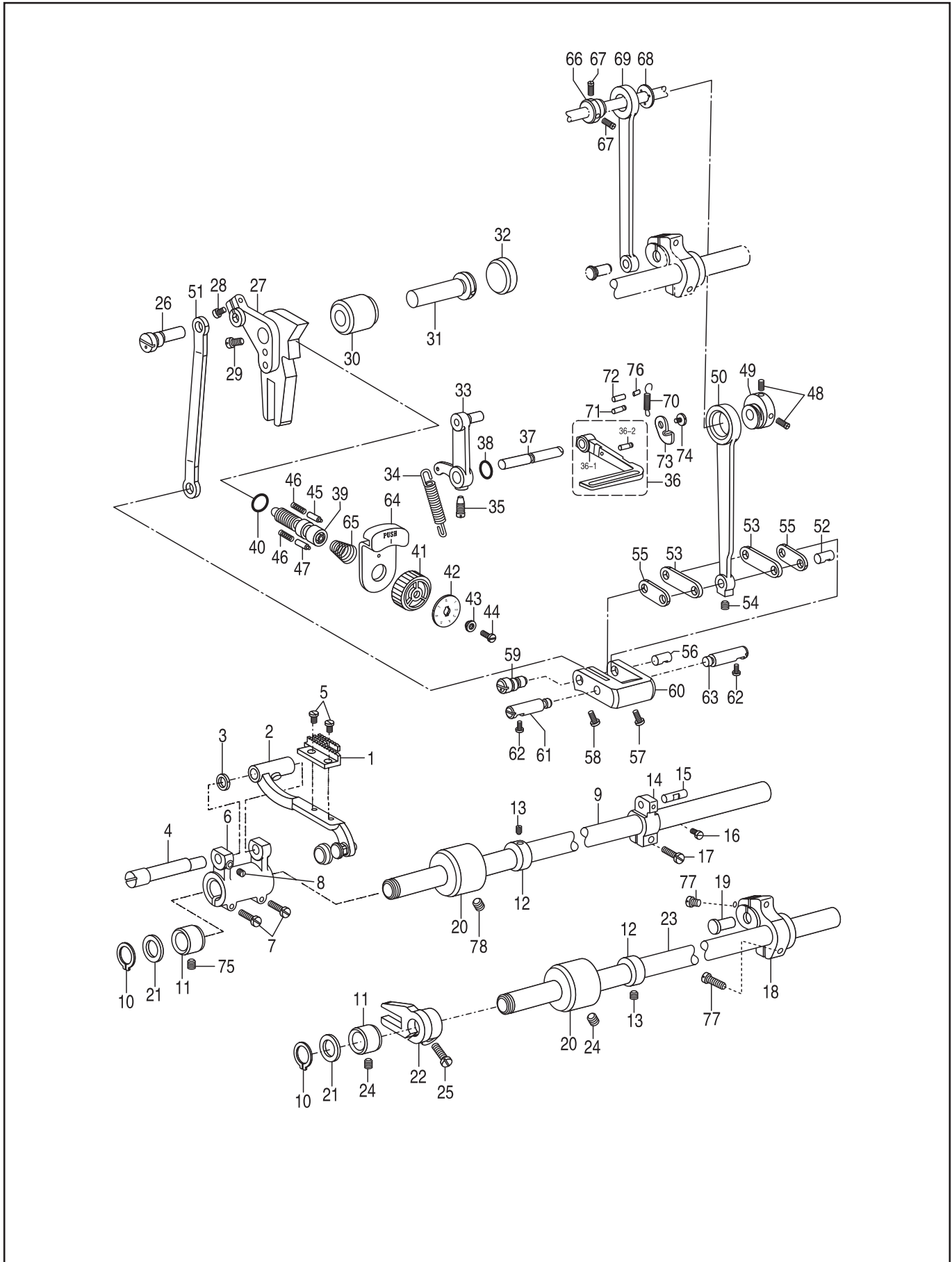

4. Feed mechanism

No.	Part number	Name	Qt.		Remark
			0303D	0303DCX	
46	22T5-009	Spring	2	2	
47	7WF2-006	Stopper pin	1	1	
48	36T3-003D ₂	Set screw	3	3	
49	36T5-008E ₁	Feed cam	1	1	
50	4WF2-009A	Feed connecting rod	1	1	
51	4WF2-009B	Connecting rod	1	1	
52	82T2-003C1a10-1	Stud	1	1	
53	36T5-008E4H02	Link	2	2	
54	36T5-008E5	Set screw	1	/	
	21WF1-060	Set screw	/	1	
55	36T5-008E4H01	Link	2	2	
56	36T5-008E6	Shaft	1	1	
57	36T5-008E7	Screw	1	1	
58	36T5-008E8	Screw	1	1	
59	36T5-008E9	Shaft	1	1	
60	36T5-008E10	Feed regulator crank	1	/	
	75WF4-006	Feed regulator crank	/	1	
61	5WF1-002	Pin shaft, L	1	1	
62	22T6-008D3	Screw	2	2	
63	5WF1-001	Pin shaft, R	1	1	
64	7WF2-005	Stopper	1	1	
65	36T5-011	Spring	1	1	
66	36T3-003D ₁	Eccentric wheel	1	1	
67	36T3-003D ₂	Screw	3	3	
68	36T3-004	Holder	1	1	
69	22T3-009D1C	Feed lifting rod	1	1	
70	2KT3-008	Spring	1	1	
71	2KT3-009	Spring hook	1	1	
72	2KT3-006	Pin	1	1	
73	2KT3-004	Plate	1	1	
74	2KT3-005	Screw	1	1	
75	J0.0.35	Screw	1	1	
76	2KT3-007	Pin shaft	1	1	
77	17WF4-021	Screw	1	1	
78	J0.0.40	Screw	1	1	

5. Upper feed mechanism

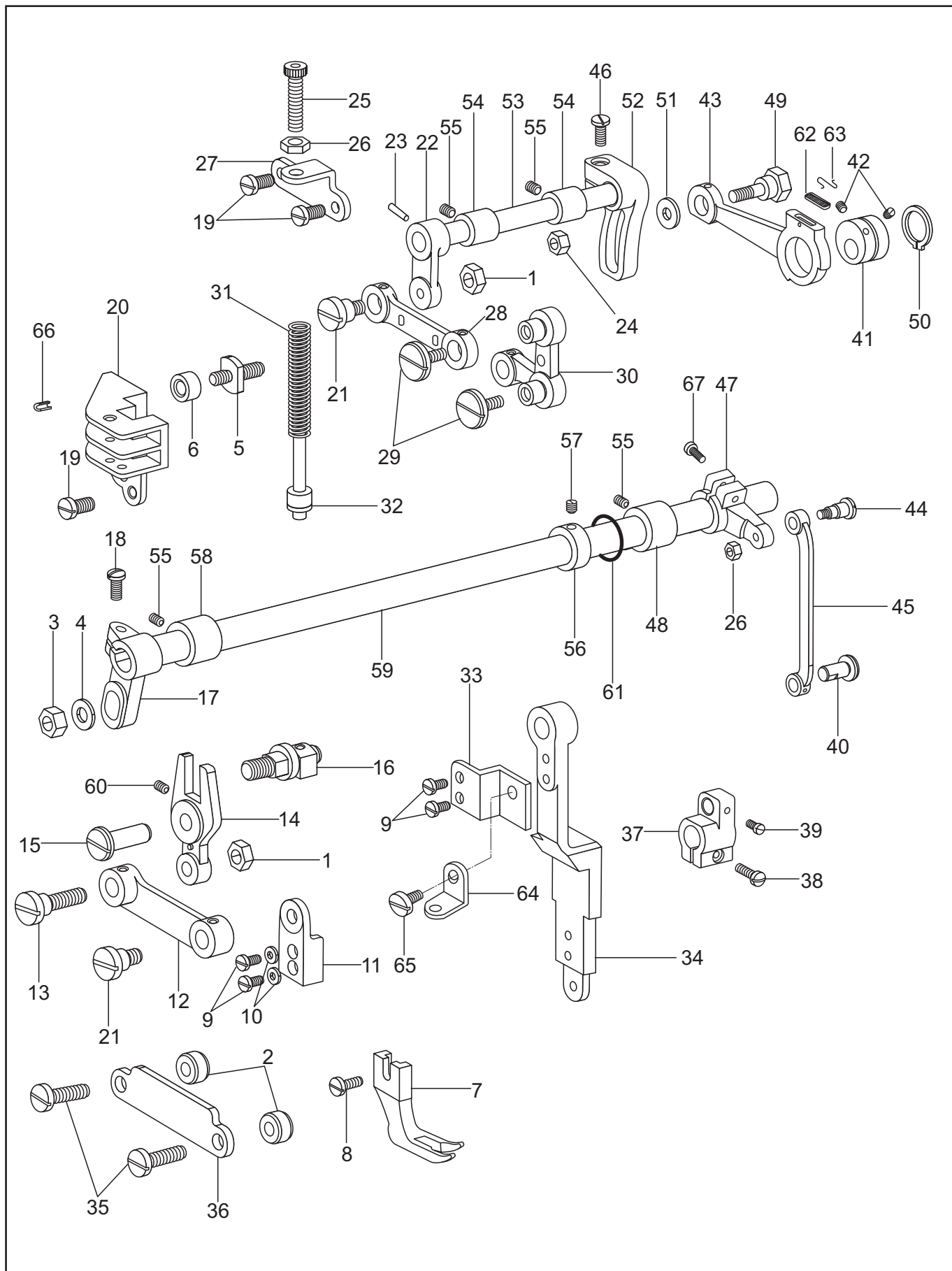

5. Upper feed mechanism

No.	Part number	Name	Qt.		Remark
			0303D	0303DCX	
1	7WF5-001	Nut	2	2	
2	7WF5-002	Collar	2	2	
3	7WF5-003	Nut	1	1	
4		Washer	1	1	GB/T95 6
5	7WF5-004	Roller shaft	1	1	
6	7WF5-005	Roller	1	1	
7	7WF5-006	Walking foot	1	/	
	11WF5-001	Walking foot	/	1	
8	61-04-01/B316	Screw	1	1	
9	7WF5-008	Screw	4	4	
10		Washer	2	2	GB93 4
11	7WF5-009	Clamper	1	1	
12	7WF5-010	Link	1	1	
13	7WF5-011	Shoulder screw	1	1	
14	7WF5-012	Lever	1	1	
15	7WF5-013	Shaft	1	1	
16	7WF5-014A	Roller shaft assy.	1	1	
17	233WF5-023	Crank	1	1	
18	1WF4-032	Screw	2	2	
19	22T2-019	Screw	4	4	
20	7WF5-018	Lever guide	1	1	
21	7WF5-019	Screw	2	2	
22	7WF5-020	Feed lifting arm crank, L	1	1	
23		Pin	1	1	GB/T117 4×20
24	7WF5-050	Nut	1	1	
25	7WF5-021	Screw	1	1	
26	7WF5-022	Nut	2	2	
27	7WF5-023	Bracket	1	1	
28	7WF5-024	Link	1	1	
29	7WF5-025	Screw	2	2	
30	258F3-005	Feed lever	1	1	
31	81WF6-003	Spring, compression	1	1	
32	81WF6-004	Guide shaft	1	1	
33	241WF3-001	Holder plate	1	1	
34	7WF5-030	Connecting rod	1	1	
35	22T6-008D ₃	Screw	2	2	
36	7WF5-031	Rod guide	1	1	
37	5WF4-002	Feed rocker arm	1	1	
38	61-04-01/B504	Screw	1	1	
39	36T5-008E ₅	Set screw	1	1	
40	5WF4-001	Stud	1	1	
41	7WF5-032	Eccentric wheel	1	1	
42	22T2-005B ₃	Screw	2	2	
43	7WF5-034	Connecting rod	1	1	
44	7WF5-037	Shoulder screw	1	1	
45	7WF5-038	Connecting rod	1	1	
46	7WF5-039	Shoulder screw	1	1	
47	241WF3-003	Feed lifting arm crank, R	1	1	
48	241WF3-005	Bush, M	1	1	
49	7WF5-042	Screw	1	1	
50		Retaining ring, C	1	1	GB894.1 25
51	7WF5-049	Washer	1	1	
52	7WF5-043	Feed arm	1	1	
53	7WF5-044	Feed lifting shaft	1	1	
54	7WF5-045	Bush	2	2	
55	61-04-01/B308	Screw	3	3	
56	22T3-002B ₁	Collar	1	1	
57	22T3-002B ₂	Screw	2	2	
58	1KT2-004	Bush, L	1	1	
59	241WF3-004	Upper feed shaft	1	1	
60	7WF5-048	Screw	1	1	
61	33T2-030-A	O ring	1	1	
62	7WF5-035	Oil felt	1	1	
63	1WF5-024	Spring	1	1	
64	241WF3-002	Bracket	1	1	
65	241WF3-006	Screw	1	1	
66	1WF5-024	Pin	2	2	GB/T879.1 3×8
67	16WF3-031	Screw	1	1	

6. Hook mechanism

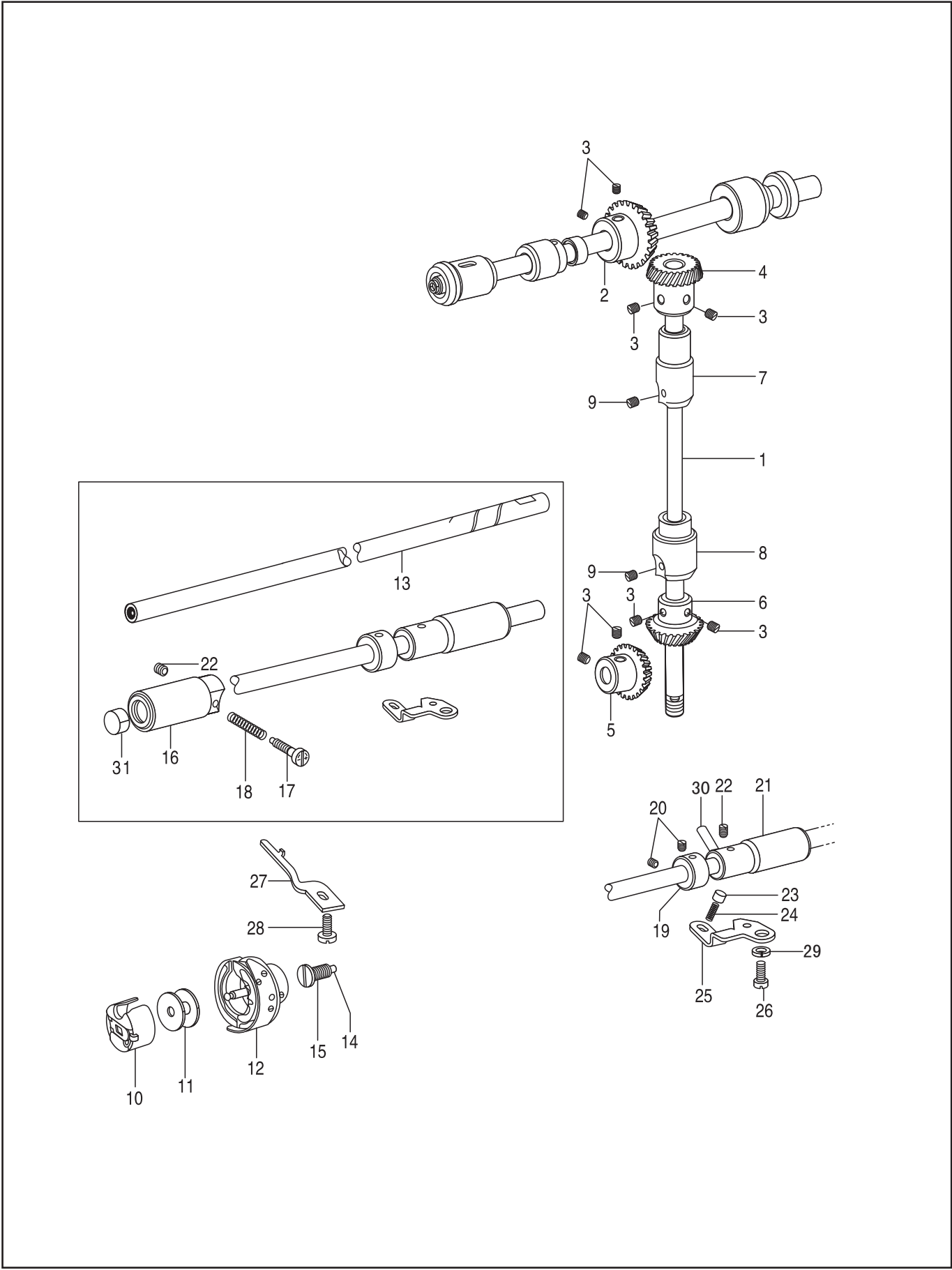

6. Hook mechanism

No.	Part number	Name	Qt.		Remark
			0303D	0303DCX	
1	15WF1-001	Vertical shaft	1	1	
2	ZOA140379	Bevel gear, upper shaft	1	1	
3	22T2-005B3	Set screw	8	8	
4	ZOA140380	Bevel gear, vertical shaft, U	1	1	
5	ZOA140383	Bevel gear, lower shaft	1	1	
6	ZOA140382	Bevel gear, vertical shaft, L	1	1	
7	2KT1-015	Bush, vertical shaft, U	1	1	
8	2KT1-008	Bush, vertical shaft, L	1	1	
9	J0.0.40	Screw	2	2	
10	33T1-028R	Bobbin case	1	/	
	11WF4-007	Bobbin case	/	1	
11	33T1-027	Bobbin	1	1	
12	33T1-008J	Hook assy.	1	/	
	11WF4-008	Hook assy.	/	1	
13	36T4-008D1	Lower shaft	1	1	
14	22T4-001A1a2	Filter	1	1	
15	22T4-001A1a1	Screw	1	1	
16	4WF1-005	Bush, lower shaft, L	1	1	
17	22T4-005	Adjusting screw, oil	1	1	
18	22T4-006	Adjusting spring	1	1	
19	22T4-002B1	Collar	1	1	
20	J0.0.35	Screw	2	2	
21	4WF1-004	Bush, lower shaft, R	1	1	
22	J0.0.5	Screw	2	2	
23	36T4-015	Plunger	1	1	
24	36T4-016	Spring	1	1	GB93 6
25	22T4-010	Holder plate	1	1	
26	22T9-006	Screw	1	1	
27	33T1-029	B/case holder position bracket	1	1	
28	22T4-015	Screw	1	1	
29		Washer	1	1	
30	22T4-007C2	Oil tube	1	1	
31	22T4-003	Oil seal	1	1	

7. Lubrication mechanism

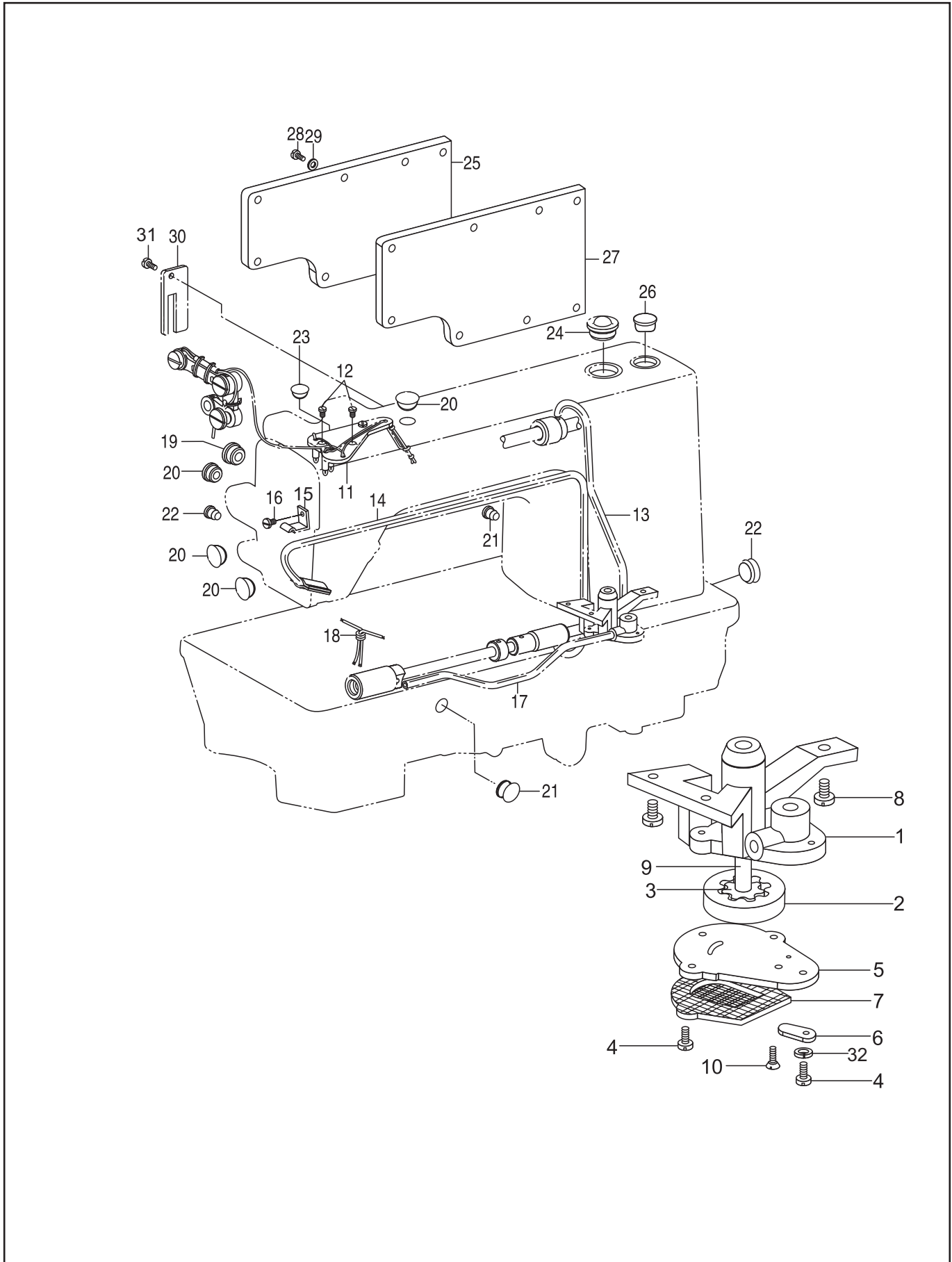

7. Lubrication mechanism

No.	Part number	Name	Qt.	Remark
1	15WF4-003	Pump body	1	
2	15WF4-006	Big gear, pump	1	
3	15WF4-007	Small gear, pump	1	
4		Screw	3	GB/T67 M3×10
5	15WF4-004	Cover	1	
6	22T8-007	Throat plate	1	
7	22T8-008A	Filter set	1	
8	22T8-009	Screw	1	
9	15WF4-005	Shaft	3	GB/T68 M3×10
10		Screw	1	
11	7WF4-016	Setting plate	2	
12	22T8-012	Oil tube, U	1	
13	22T8-013D	Tube assy.	2	
14	242WF1-004	Tube carrier	1	
15	22T8-016	Screw	1	
16	20T4-006	Oil tube, L	1	
17	4WF4-005A	Oil wick	1	
18		Rubber cap	1	
19	22T1-003C3	Rubber cap	1	
20	22T1-003C4	Rubber cap	1	
21	22T1-015	Rubber cap	4	
22	22T1-016	Oil gauge window	2	
23	22T1-017	Back cover	1	
24	22T1-008	Rubber cap	1	
25	241WF1-005	Packing	1	
26	13WF2-035	Screw	1	
27	241WF1-006	Washer	1	GB93 4
28	22T1-006	Oil stopper	8	
29	22T1-007	Screw	8	
30	7WF4-011	Washer	1	
31	33T3-006		1	
32			1	

8. Accessories

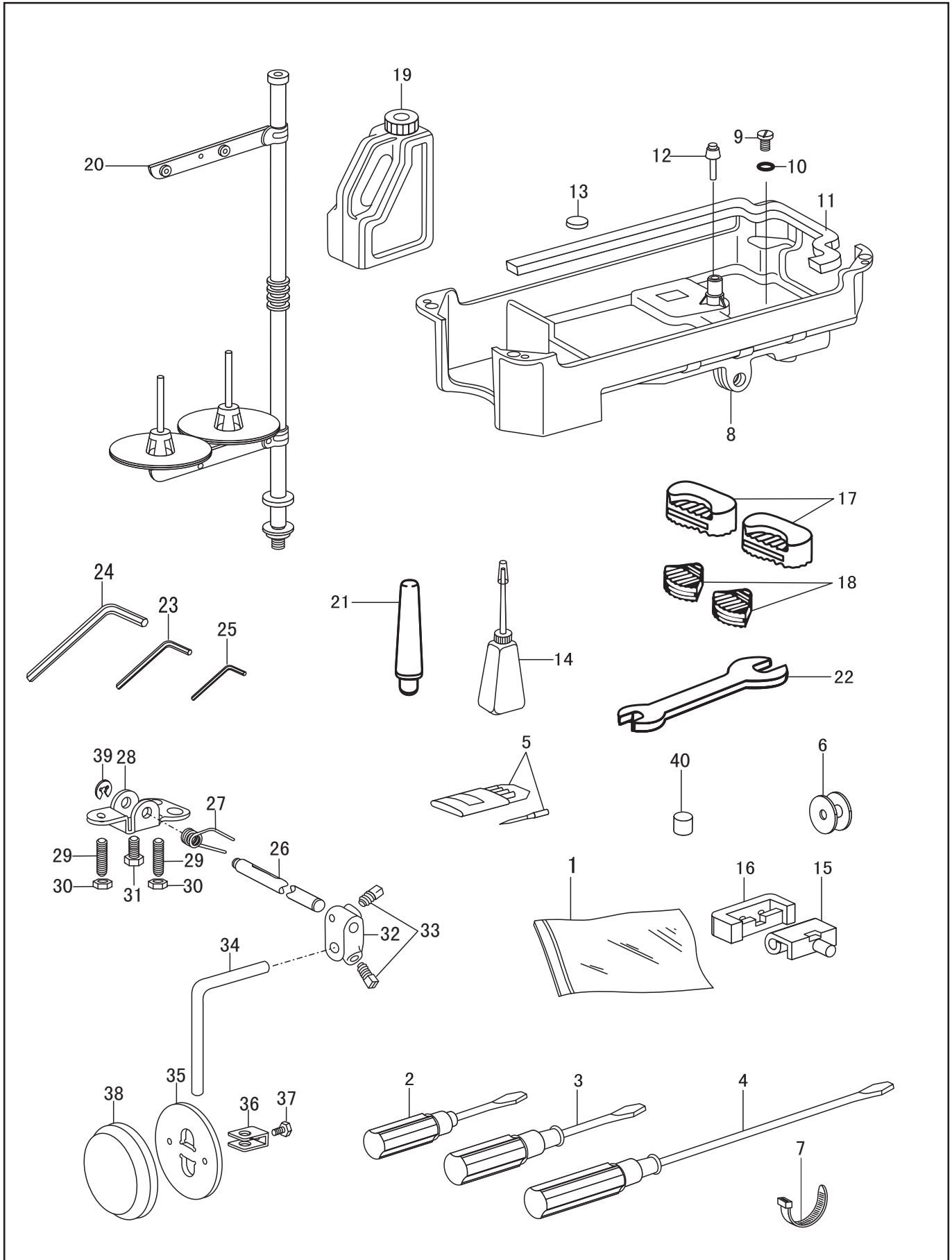

8. Accessories

No.	Part number	Name	Qt.		Remark
			0303D	0303DCX	
1	33TF-010	Accessory bag	1	1	
2	33TF-014	Screw driver, S	1	1	
3	33TF-013	Screw driver, M	1	1	
4	33TF-012	Screw driver, L	1	1	
5		Needle	4	-	DPX17 23#
		Needle	-	4	DPX17 25#
6	33T1-027	Bobbin	3	3	
7	129WF1-016	Band	3	3	
8	4WF5-001	Oil pan	1	1	
9	22T9-001A2	Screw	1	1	
10	22T9-001A3	Washer	1	1	
11	2KT9-008	Packing, oil pan	1	1	
12	4WF5-002	Lifter bar, knee	1	1	
13	22T9-012	Magnet	1	1	
14	33TF-011	Oil pot	1	1	
15	22T9-007F1	Head hinge	2	2	
16	22T9-007F2	Cushion, head hinge	2	2	
17	1KT5-004	Head cushion, L	2	2	
18	1KT5-003	Head cushion, S	2	2	
19	1F-012	Oil tank	1	1	2 GB/T5356-1998
20	4F-007	Thread stand assy.	1	1	3 GB/T5356-1998
21	1KT5-007	Head rest	1	1	2.5 GB/T5356-1998
22		Wrench	1	1	
23		Wrench, 2mm	1	1	
24		Wrench, 3mm	1	1	
25		V-belt	1	1	
26	22T9-001A6	Lifter shaft	1	1	
27	22T9-001A7	Spring	1	1	GB/T5781 M8×12 M8×20
28	22T9-001A8	Bracket	1	1	
29	22T9-001A9	Adjusting screw	2	2	
30	22T9-001A10	Adjusting nut	2	2	
31	22T9-036	Screw	1	1	
32	22T9-003B3	Bracket	1	1	
33		Screw	1	1	GB896 9
34	22T9-003B2	Lifter bar	1	1	Φ8×3.5
35	22T9-003B5	Knee lifter plate	1	1	
36	22T9-003B6	Stopper	1	1	
37	22T9-003B7	Screw	1	1	
38	22T9-003B8	Cover, K-lifter plate	1	1	
39		Retaining ring	1	1	
40		Safety switch magnet	1	1	